

External Grant Award Number: 02HQGR0004

**COLLABORATIVE RESEARCH WITH THE UNIVERSITY
OF MEMPHIS AND THE USGS; DOWNHOLE SEISMIC
INSTRUMENTATION AT THE I-40 MISSISSIPPI RIVER
BRIDGE IN MEMPHIS, TENNESSEE**

Shahram Pezeshk
Department of Civil Engineering
The University of Memphis
Memphis, TN 38152
Phone: (901) 678-4727
Fax: (901) 678-3026
Email: spezeshk@memphis.edu

and
Greg Steiner
Center for Earthquake Research and Information
The University of Memphis
Memphis, TN 38152
Phone: (901) 678-4955
Fax: (901) 678-4734
Email: steiner@ceri.memphis.edu

Abstract

External Grant Award Number: 02HQGR0004

COLLABORATIVE RESEARCH WITH THE UNIVERSITY OF MEMPHIS AND THE USGS; DOWNHOLE SEISMIC INSTRUMENTATION AT THE I-40 MISSISSIPPI RIVER BRIDGE IN MEMPHIS, TENNESSEE

Shahram Pezeshk
Department of Civil Engineering
The University of Memphis
Memphis, TN 38152
Phone: (901) 678-4727
Fax: (901) 678-3026
Email: spezeshk@memphis.edu

and
Greg Steiner
Center for Earthquake Research and Information
The University of Memphis
Memphis, TN 38152
Phone: (901) 678-4955
Fax: (901) 678-4734
Email: steiner@ceri.memphis.edu

The purpose of this project was to purchase and install two downhole triaxial sensors to complement a strong motion instrumentation system planned to be deployed on and in the vicinity of the I-40 Hernando DeSoto Mississippi River Bridge in Memphis, Tennessee. This bridge is being retrofitted to withstand a magnitude (m_b) 7 event at 65 km distance from the site at a depth of 20 km. The goal of the retrofit is to have this bridge fully operational following the maximum probable earthquake (2500 year return period). As part of the I-40 bridge retrofit, Friction Pendulum™ Isolation Bearings will be used to insure the integrity of the main spans of the bridge.

Two downhole systems have been purchased to complete the seismic instrumentation of the I-40 Bridge (see Figure 1). These downhole systems consist of a triaxial accelerometer and a triaxial broadband velocity seismometer with 2-channel inclinometer. The sensors will be installed on the pile caps in Pier C (Figure 2) and Pier 28 (Figure 3) and will record the foundation motion, including the effect of soil-structure interaction, in two horizontal directions and a vertical direction. An estimate of the soil-structure interaction effect may be obtained by comparing the motion recorded at the bridge foundation and in the free field.

2.0 SIGNIFICANCE OF THE PROJECT

Memphis and Shelby County, Tennessee, are located geographically close to the southwestern segment of the New Madrid seismic zone (NMSZ), which is regarded by seismologists, engineers, and public officials as the most hazardous seismic zone in the Eastern United States. Thus, Memphis and Shelby County are potentially exposed to significant seismic hazards. A large earthquake occurring anywhere within the NMSZ could cause widespread loss of life with damage to buildings, bridges, and lifelines due to ground shaking and ground failure induced by the earthquake.

The purpose of this project was to purchase and install two additional downhole triaxial sensors to complement a seismic instrumentation system planned to be deployed on and in the vicinity of the I-40 Hernando DeSoto Mississippi River Bridge in Memphis, Tennessee. This bridge is being retrofitted to withstand a magnitude (m_b) 7 event at 65 km distance from the site at a depth of 20 km. The goal of the retrofit is to have this bridge fully operational following the maximum probable earthquake (2500 year return period). As part of the I-40 bridge retrofit, Friction Pendulum™ Isolation Bearings will be used to insure the integrity of the main spans of the bridge.

The I-40 bridge is being retrofitted in several phases. Therefore, there is a window of opportunity to install an integrated system of seismic strong-motion instruments in and around the vicinity of the bridge during the retrofit construction phase. The Tennessee Department of Transportation (TDOT) in conjunction with the Federal Highway Administration (FHWA) provided funding to install strong-motion instrumentation with 121 data channels at 36 different locations on the bridge. The instrumentation that was funded by TDOT and FHWA monitors the structural part of the bridge. The U.S. Geological Survey (USGS) provided the funding to purchase and install two downhole systems to complete the seismic instrumentation of the I-40 Bridge. TDOT absorbed the cost of the installation of piping system and conduits needed to house the downhole seismic sensors. A downhole seismic sensor will be installed at each footing about 95 ft below the bottom of the existing riverbed and about 130 ft below the high water level.

Currently, in the United States and elsewhere in the world, there are very little data available on the response of long-span bridges during seismic events. Since such data are scarce, our ability to understand the behavior of such structures and to verify dynamic analyses performed on such structures during design/analyses/retrofit phases is limited. In the NMSZ, there are no long-span bridge structures currently instrumented. Therefore, data collected from instrumentation of the I-40 bridge in Memphis will be an invaluable asset in evaluating the structure. The data will be used to assess the performance of the bridge following the retrofit and in particular for the assessment of the performance of the base-isolation system. In addition, data collected on the behavior of the base-isolation system will be applicable to any structure incorporating the system. Furthermore, lessons that will be learned from instrumentation of a bridge such as the I-40 bridge will provide important and needed information that will be applicable to structures built in similar seismological and geological settings as the I-40 bridge.

The I-40 bridge strong-motion instrumentation system with 121 data channels at 36 different locations incorporating the proposed downhole sensors will provide an ample number of sensors to reconstruct the behavior of the structure in sufficient detail to verify the response predicted by mathematical models. Data collected from smaller earthquakes can be used to develop an improved mathematical model of the bridge. Furthermore, a well-instrumented structure with a complete set of recordings should provide useful information to:

1. check the appropriateness of the dynamic model in the elastic range,
2. determine the importance of nonlinear behavior on the overall and local response of the structure,
3. follow the spreading nonlinear behavior throughout the structure as the response increases and determine the effect of this nonlinear behavior on the frequency and damping,
4. correlate the actual damage of the structure to predicted damage from inelastic behavior models,
5. determine the ground-motion parameters that correlate well with bridge response and/or damage,
6. collect data at the ground level using free-field sensors and at the foundation level using the downhole sensors, and use data to determine site amplification factors and site response,
7. quantify the soil-structure interaction (this is particularly important for the I-40 bridge which is located on 3,000 feet of sediment), and
8. make recommendations to improve seismic codes and/or future bridge designs.

An improved model of the I-40 bridge can be used to predict potential damage/failure that the structure may experience during larger seismic events. An accurate bridge model will be a cost-effective approach to evaluate the retrofit scheme, to investigate ways to improve bridge performance, and to reduce the possibility of catastrophic failure during a large seismic event. A good example is the data recorded from the Vincent-Thomas Bridge in Los Angeles Harbor. The vertical acceleration record obtained from the center of the side span of the bridge during the Northridge earthquake is shown in Figure 1. This location recorded the largest peak acceleration. Figure 1 also shows amplitude spectra for two 40-second bands (20-60 second and 80-120 second) (Celebi, paper in preparation). These two bands exhibit two distinctive frequencies suggesting that some form of deformation occurred in the mid-span to alter its frequency. As a result of studies conducted on the bridge, including those that utilized this record, a retrofitting program was adopted. Furthermore, as a result of the recorded data, deficiencies in the bridge were realized and a retrofit program was developed that will eliminate possible failure

during a larger event. Lessons learned from studying the data obtained from this bridge will continue to provide important information on how to retrofit other structures in similar seismological and geological settings.

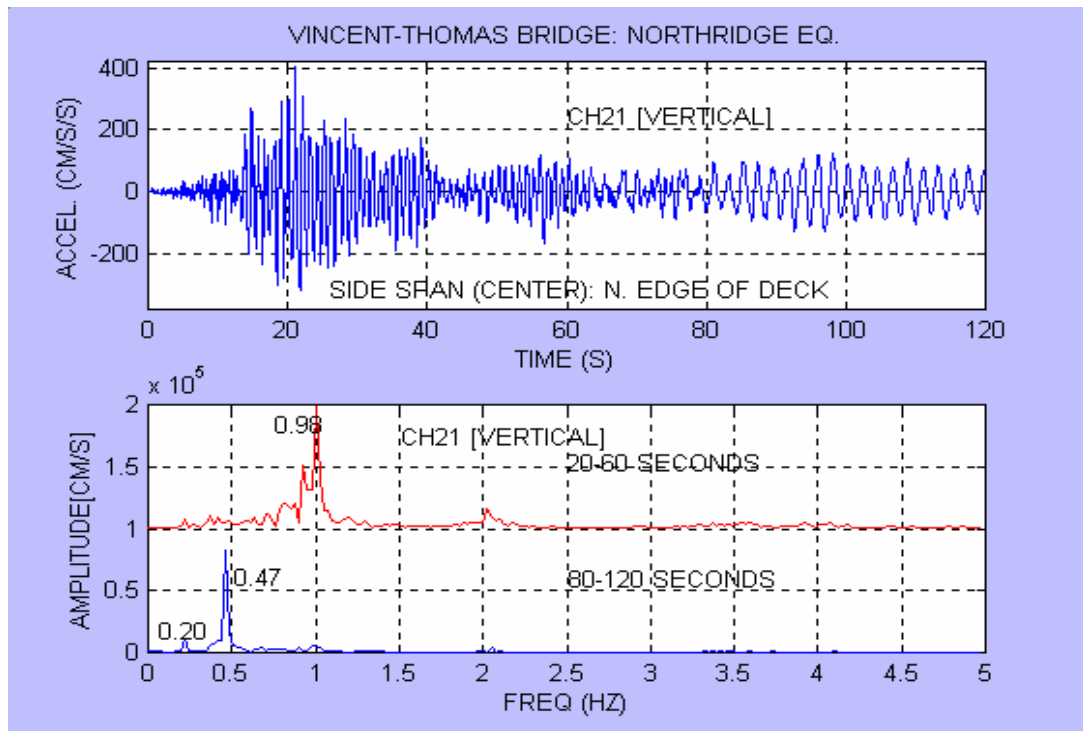

Figure 1. The recorded acceleration time-history of vertical motions at center of side-span exhibited the largest peak acceleration during the 1994 Northridge earthquake. This record also shows that the frequency of the bridge changed drastically (to 0.47 Hz) during the last 40 seconds of the record as compared to the 20-60 second band (0.98 Hz).

3.0 PROJECT PLAN

We plan to install 121 sensors on the I-40 Hernando Desoto Mississippi River Bridge in Memphis, Tennessee to fully characterize the response of the bridge to strong ground motion. Borehole sensors will be added to monitor the ground motion at the foundation level located approximately 95 ft below the bottom of the existing riverbed and about 130 ft below the high water level. The location of the I-40 bridge is shown in Figure 2. The general location and sensing directions for sensors on the main span are marked in Figure 3. Figure 4 shows Arkansas-side approach spans. Figure 4 also shows the general location and sensing direction for sensors on the approach spans. The information to be measured from the sensors includes: (1) free-field ground motion near the instrumented bridge, (2) motion of the bridge foundation, (3) site response, (4) motion of the bridge below the isolation bearings, (5) motion of the bridge above the isolation bearings, (6) the spatial variation of ground motion along the total span; and (7) lateral and torsional motion of the bridge.



MEMPHIS AND SHELBY
COUNTY, TENNESSEE

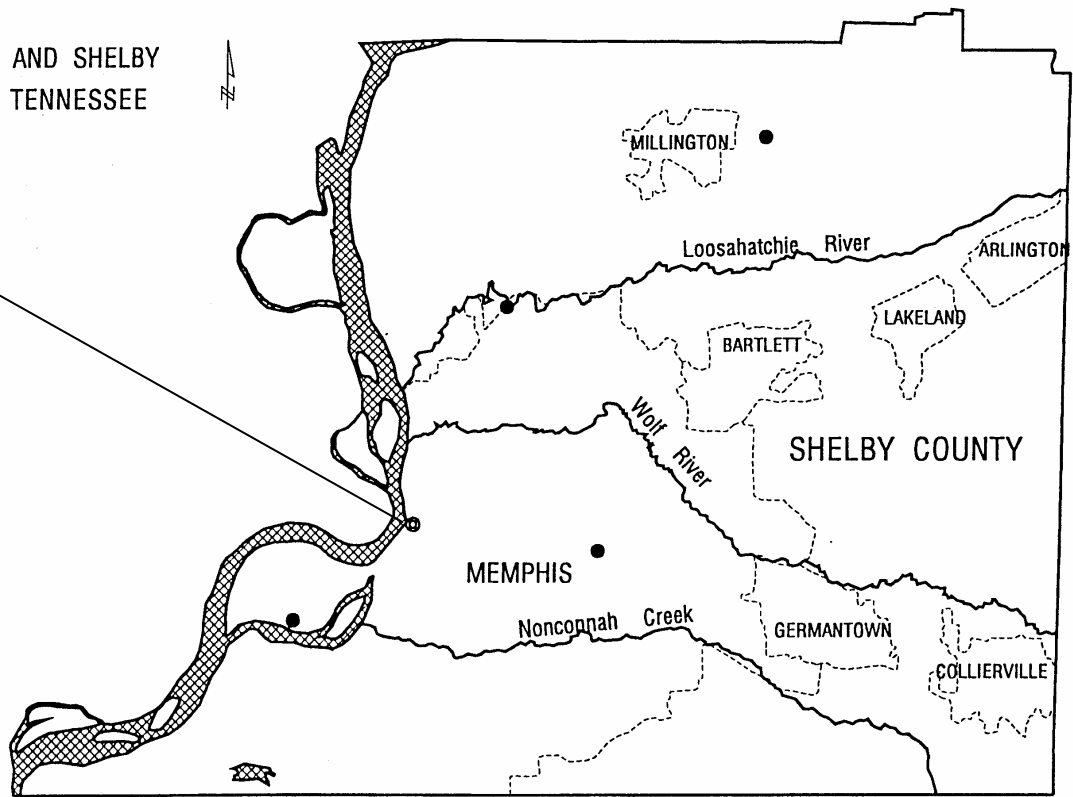

Figure 2. Location of the I-40 Hernando Desoto Mississippi River Bridge.

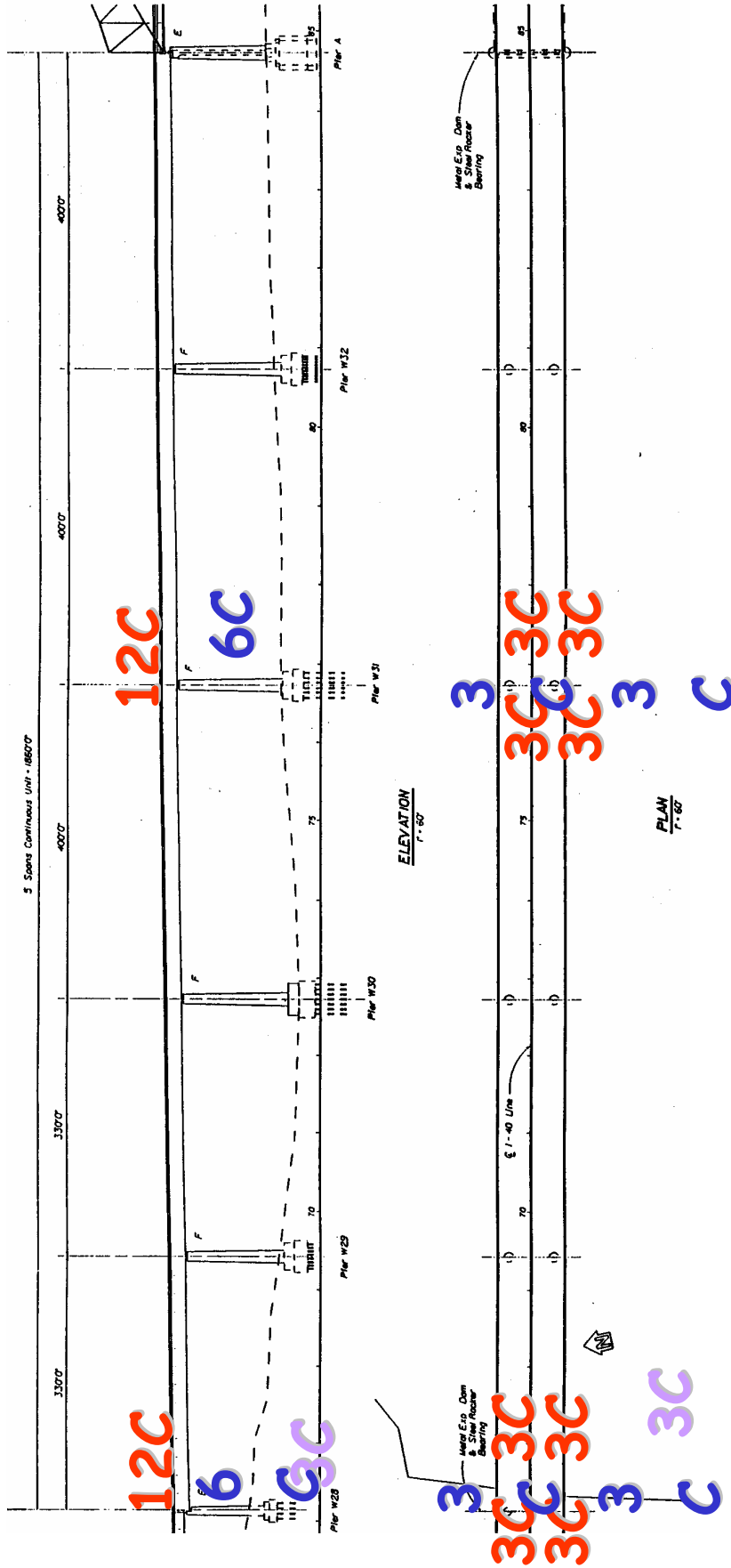

Figure 4. West Approach to the I-40 Bridge and Sensor Locations.

3.1 Measurement of Free-Field Motion

The free-field ground motion is the basic required information for a seismic response analysis of the bridge. It can be measured by two triaxial accelerometers located on Mud Island near the main span of the bridge in Tennessee and in a service area near the approach span in Arkansas (see Figure 5). These sensors record the ground motion in two horizontal directions and in the vertical direction. Placing free-field sensors on Mud Island and near the bridge in Arkansas will help avoid the effect of structural response (soil-structure interaction) on the recorded ground motion.

The free field sensors have been installed and are being operated through funds from the Advanced National Seismic System (ANSS).

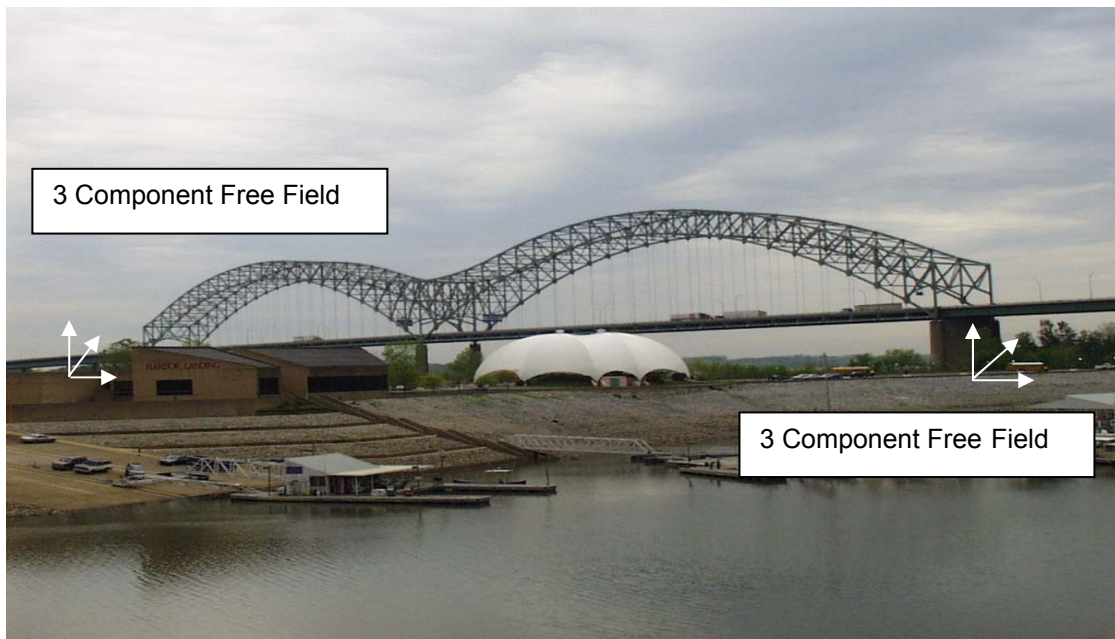

Figure 5. Mud Island and the location of the free field sensors.

3.2 Measurement of Bridge Foundation Motion

Two downhole systems have been purchased to complete the seismic instrumentation of the I-40 Bridge (see Figure 6). These downhole systems consist of a triaxial accelerometer and a triaxial broadband velocity seismometer and a 2-channel inclinometer (used to measure static tilt of installed broadband). One sensor (three channels of accelerometers and 3 channels of broadband velocity seismometers) will be installed on the pile cap in Pier C (Figure 7). The other was supposed to be installed at Pier 28 (Figure 8). However, due to the construction problems at Pier 28, the piping system installed to house the borehole sensors was bent slightly. Initially, it was thought that the small curvature in the pipe would not be a problem. However, the curvature in the pipe was much more localized so that we cannot lower the downhole instrumentation

package to the foundation level. This was discovered using a prototype borehole sensor, which was built with the exact dimension as the actual downhole sensor (see Figure 9). We tried to lower this prototype sensor in the piping systems and were not successful. It was decided to keep and use one of the downhole instrumentations to install at Pier A or B, which are planned to be retrofitted within next year. Meanwhile, we are planning to install only a 3-component borehole accelerometer without the broadband at Pier 28 to take advantage of existing piping system.

These borehole sensors will record ground motion at the foundation level in two horizontal directions and the vertical direction. An estimate of the soil-structure interaction effect may be obtained by comparing the motion recorded at the bridge foundation to that in the free field. In addition, in the event of an earthquake, we can use the data collected by the downhole sensors and the free field to determine the soil amplification effects at the bridge site.

Triaxial Accelerometer portion Eentec model EA-140 sensor



Force balance sensor design
Sensor Orientations: Vertical plus two orthogonal horizontal components
Cross Axis Sensitivity: .02G per G
Frequency Response: DC TO 50 Hz
Dynamic Range:140dB
Clip Level: +/- 2G
Power requirement +/- 12 VDC at 30 mA. maximum
Output Voltage: +/- 10VDC single ended for full scale
Dynamic self test Capability
Vibration Survival: 5G rms 20 – 2000Hz
Shock Survival:100G 11ms.

Triaxial Broadband velocity seismometer portion PMD model 103 sensor

Sensor Orientations: Vertical plus two orthogonal horizontal components, Frequency Response: 0.05 to 5 Hz.
Sensor noise floor at 1 Hz –140 dB minimum (power spectral density), Clip Level +/- 10mm/sec
Output Voltage: +/- 7.5VDC differential for full scale
No remote mass centering or mass locking, Operable with base tilt to +/- 15 degrees, Power requirement + 12 VDC at 10 mA. maximum

Biaxial inclinometer

Range: +/- 25 degrees
Output voltage: 100mV per angular degree
Power requirements: + 12 VDC 10mA maximum

Figure 6. Custom shallow borehole packages incorporating triaxial broadband and accelerometer sensor components.

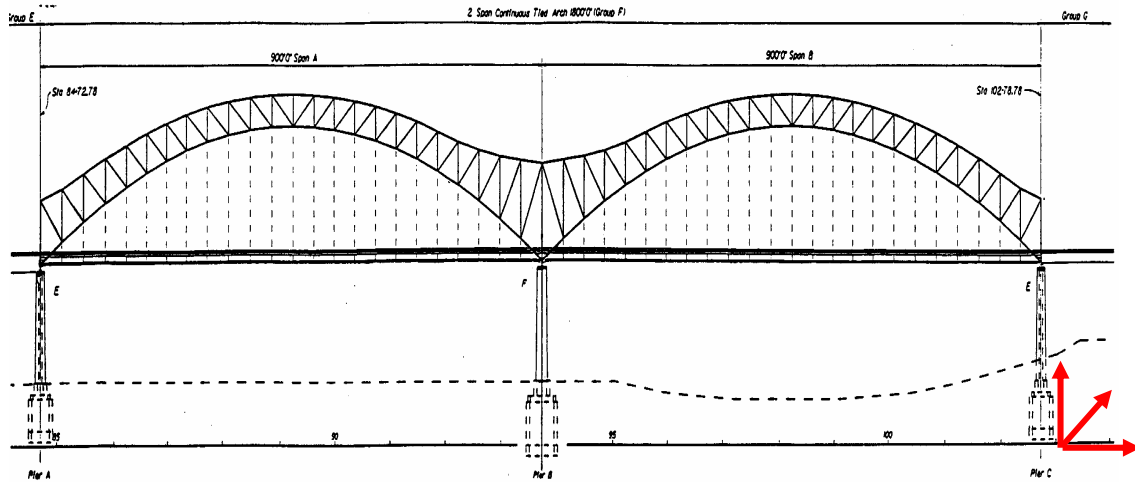

Figure 7. Downhole Sensor Location at Pier C.

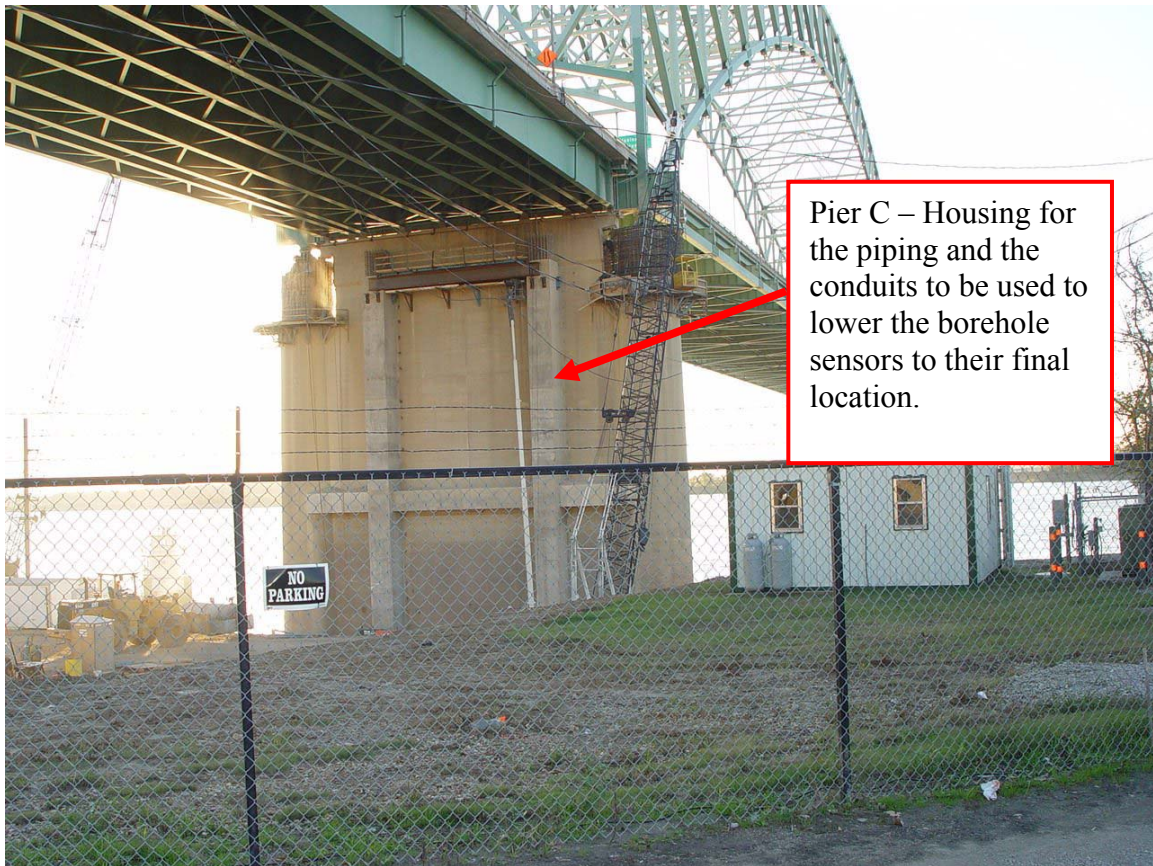

Figure 8. The location where the piping and conduits are housed for the installation of the downhole instruments at Pier C.

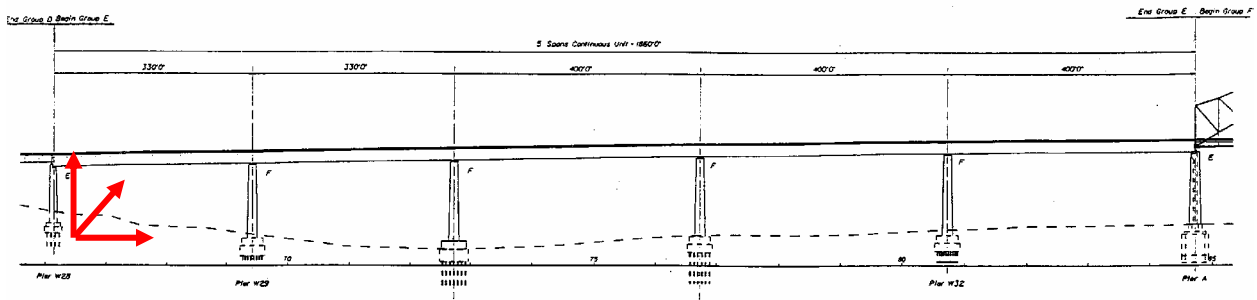

Figure 8. Sensor Location at Pier 28.



Figure 9. A prototype Borehole Sensor

3.3 Measurement of Bridge Motion

The bridge motion can be measured by sensors in transverse, longitudinal, and vertical directions as shown in Figure 3. These sensors will record the motion at bridge piers above and below their isolation bearings and at the mid-spans of the main span. These sensors will measure transverse, longitudinal, and vertical motions of approach spans. Using data recorded by these sensors, we can establish the dynamic characteristics of the bridge, such as vibrational mode shapes, structural periods, and main span deflections in the longitudinal, the transverse, and the vertical direction. The torsional response will be estimated from the motion recorded by pairs of sensors placed on opposite sides of the bridge deck. In addition, four rotational sensors will be installed at each side of mid-span of the main span. The effect of base-isolation will be estimated by comparing the motion recorded above and below the isolation bearings.

3.4 Installation

The installation of sensors will be performed by staff from The University of Memphis during the fall of 2003.

3.5 Power System Design Philosophy

Low-noise FBA type sensors will be utilized at all locations on the pier caps and at some locations on the bridge deck. The significantly quieter locations in the bridge footing will be monitored using lower noise EA-140 FBA accelerometers. All of the sensors will be connected to 22-bit digital, multi-channel recorders located at seven locations on the bridge. Data from these recorders will be digitally telemetered using 2.4 GHz WLAN cards to an existing recording site located at the Autozone Headquarters building on the riverfront.

The sensor system will be configured with individual power systems for each digital recorder telemetry site. Furthermore each of the seven recording and telemetry sites will have sufficient battery supplied back up power to provide for two to three days of operation after an AC line failure.

3.6 Maintenance

The Center for Earthquake Research and Information (CERI) at The University of Memphis will maintain the system for 10 years.

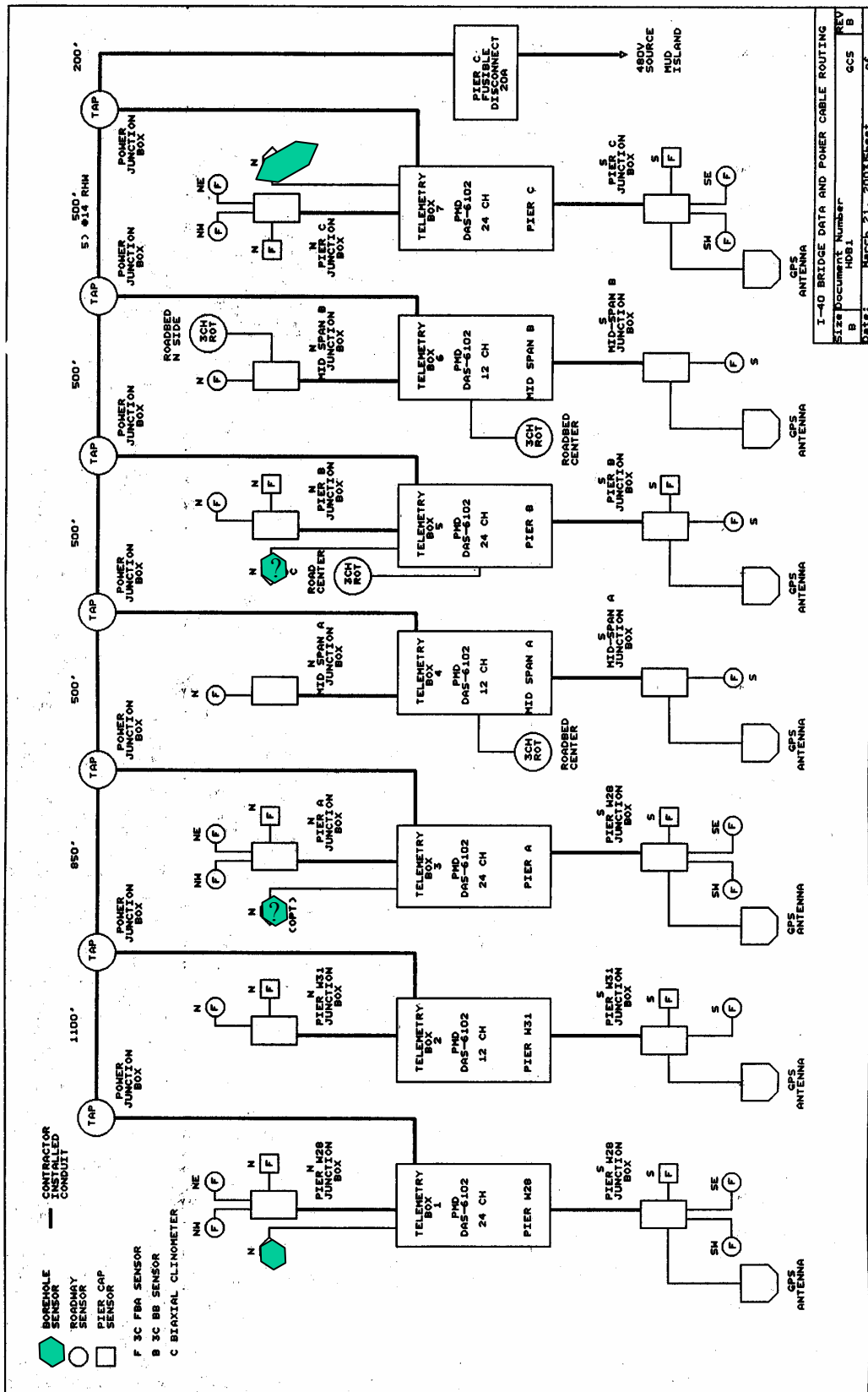

Figure 7. Proposed Data and Power Cable Routing.

4. Bibliography

1. Pezeshk, S., M. Celebi, H. Hwang. (1999). "Seismic Instrumentation of the I-40 Mississippi River Bridge in Memphis, Tennessee." NATO Advanced Research Workshop on Strong Motion Instrumentation for Civil Engineering Structures, Istanbul, Turkey, June 1-5.
2. Pezeshk, S., G. Steiner, H. Hwang, C.V. Camp, M. Celebi. (2001) "Seismic Instrumentation of the Hernando Desoto Bridge in Memphis, Tennessee." The 3rd Annual MAESC, May 11, Memphis, Tennessee.
3. Pezeshk, S., G. Steiner, and M. Celebi. (2002). "Seismic Instrumentation of the I-40 River Bridge in Memphis, Tennessee." *Seventh U.S. National Conference on Earthquake Engineering (7NCEE)*, Boston, Massachusetts, July 21-25, CD-ROM.