

Mohr Circles

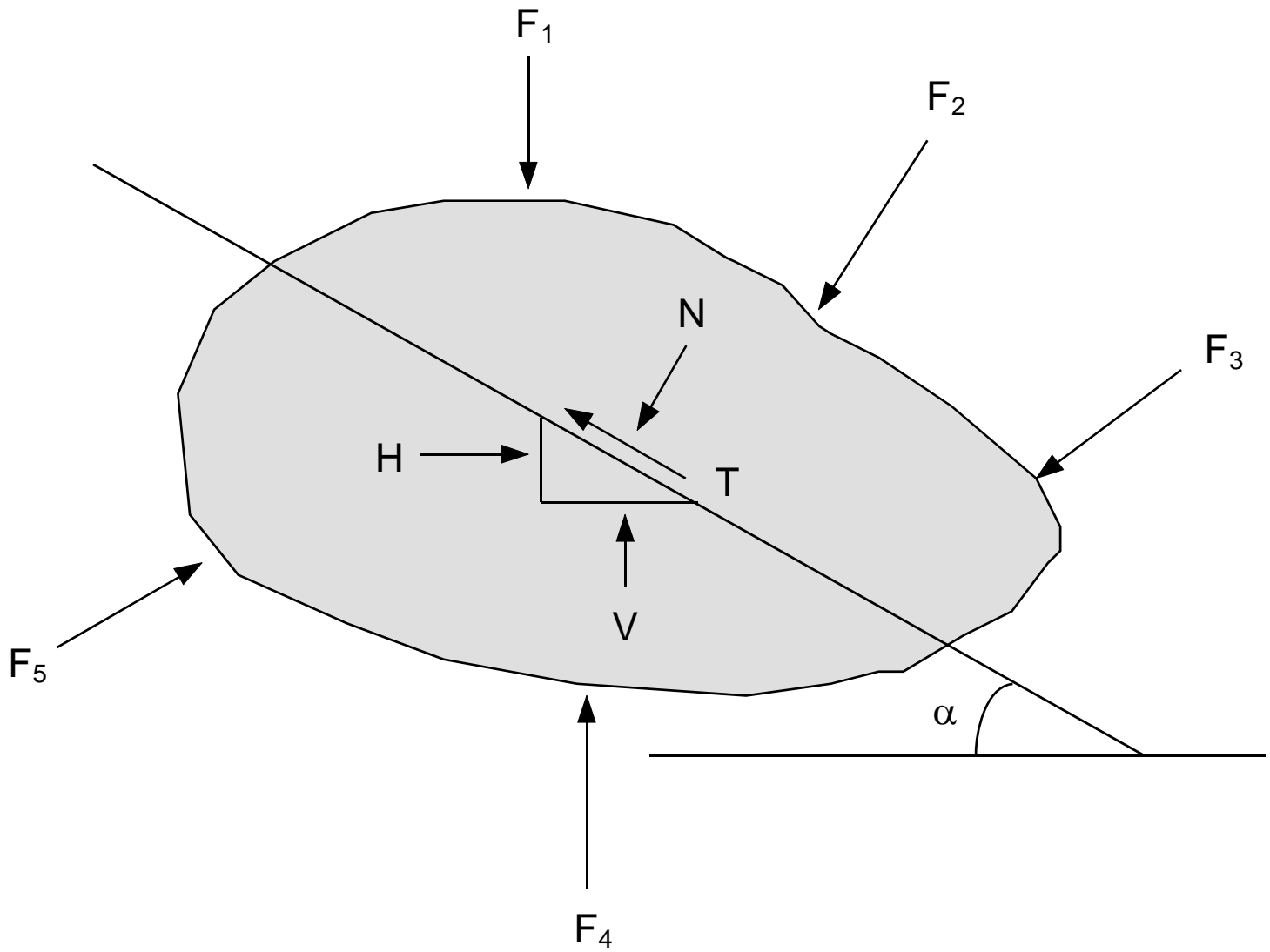

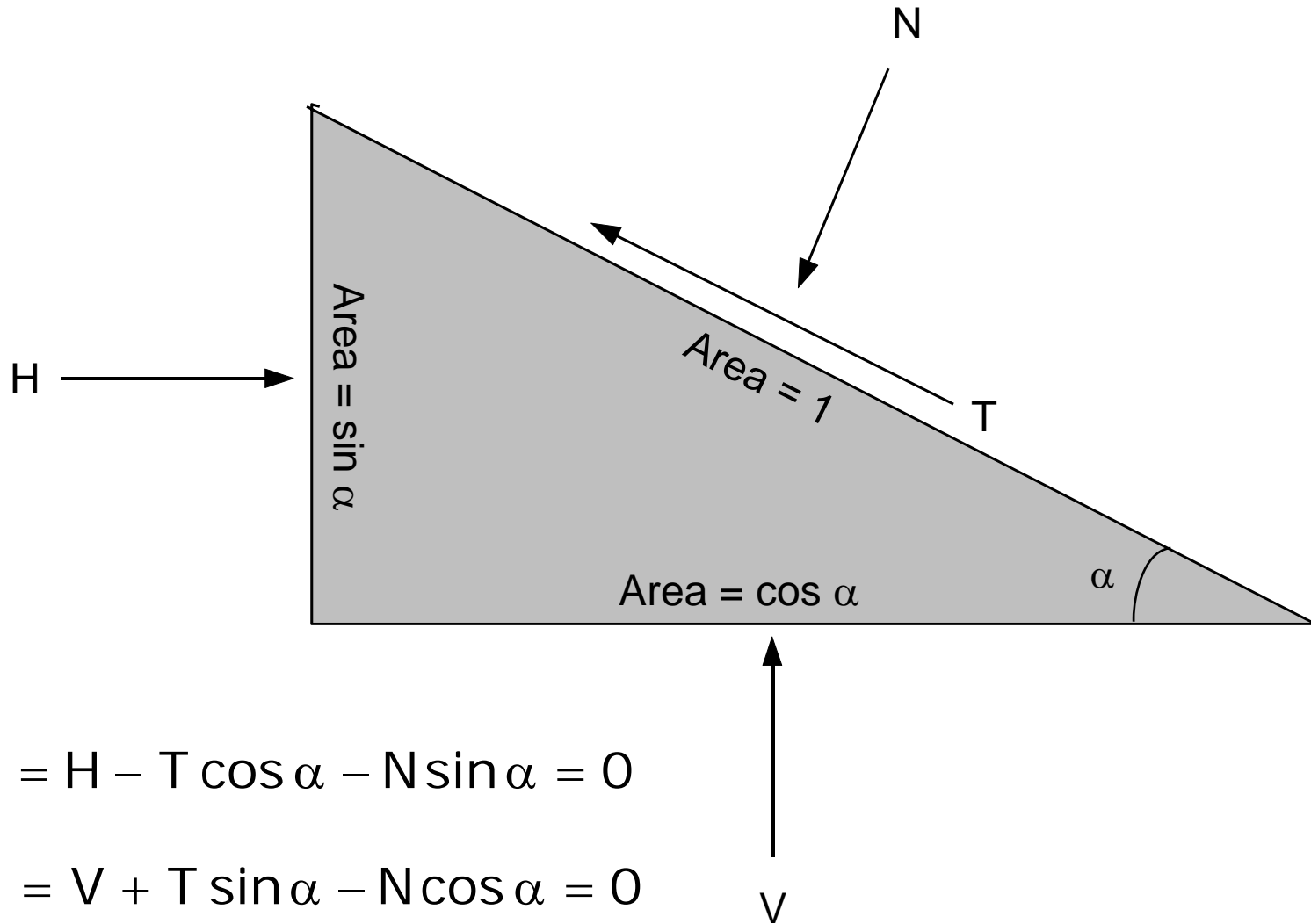

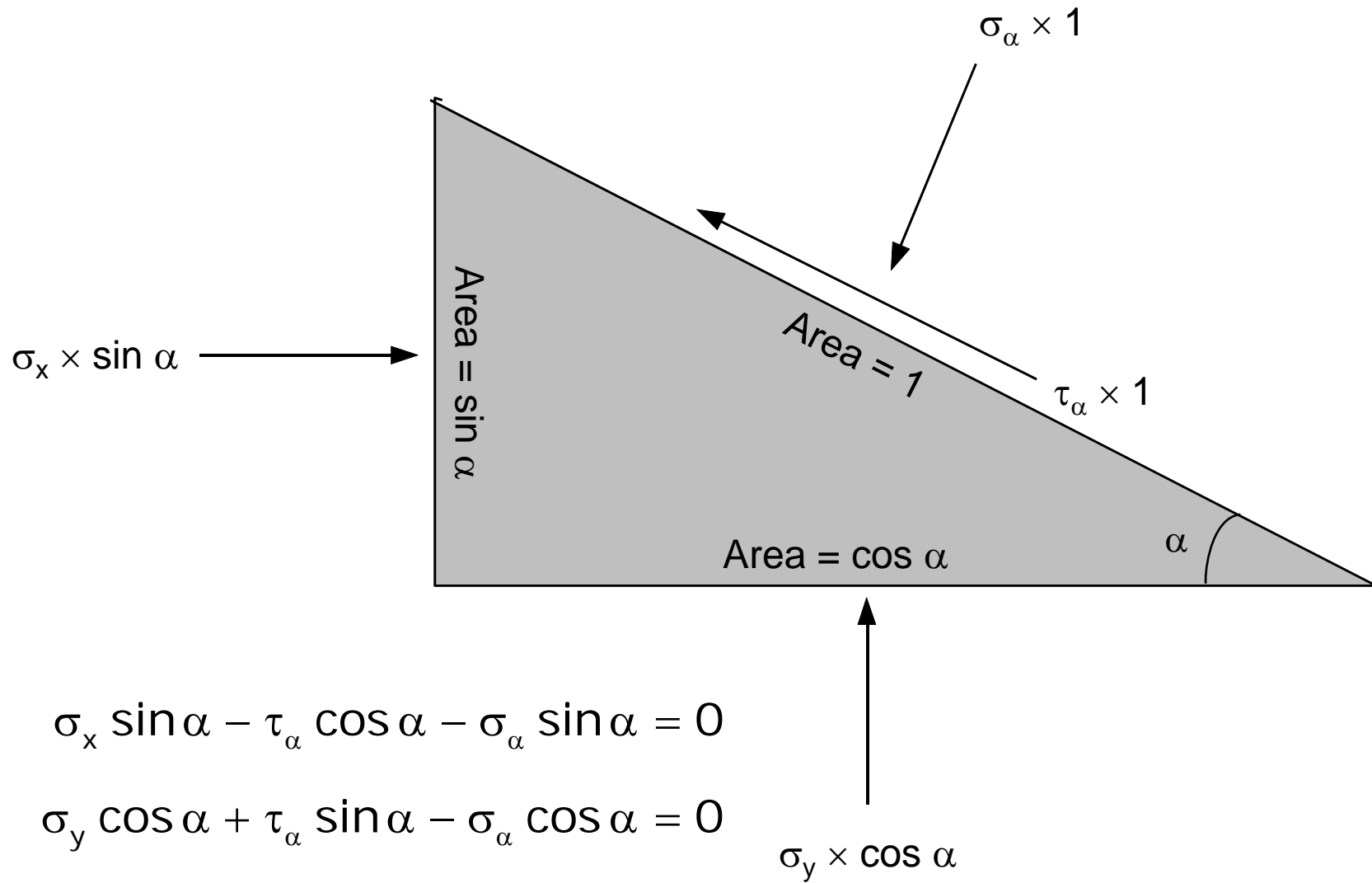

Double Angle Formulas

$$\sigma_{\alpha} = \frac{\sigma_x + \sigma_y}{2} + \frac{\sigma_x - \sigma_y}{2} \cos 2\alpha$$

$$\tau_{\alpha} = \frac{\sigma_x - \sigma_y}{2} \sin 2\alpha$$

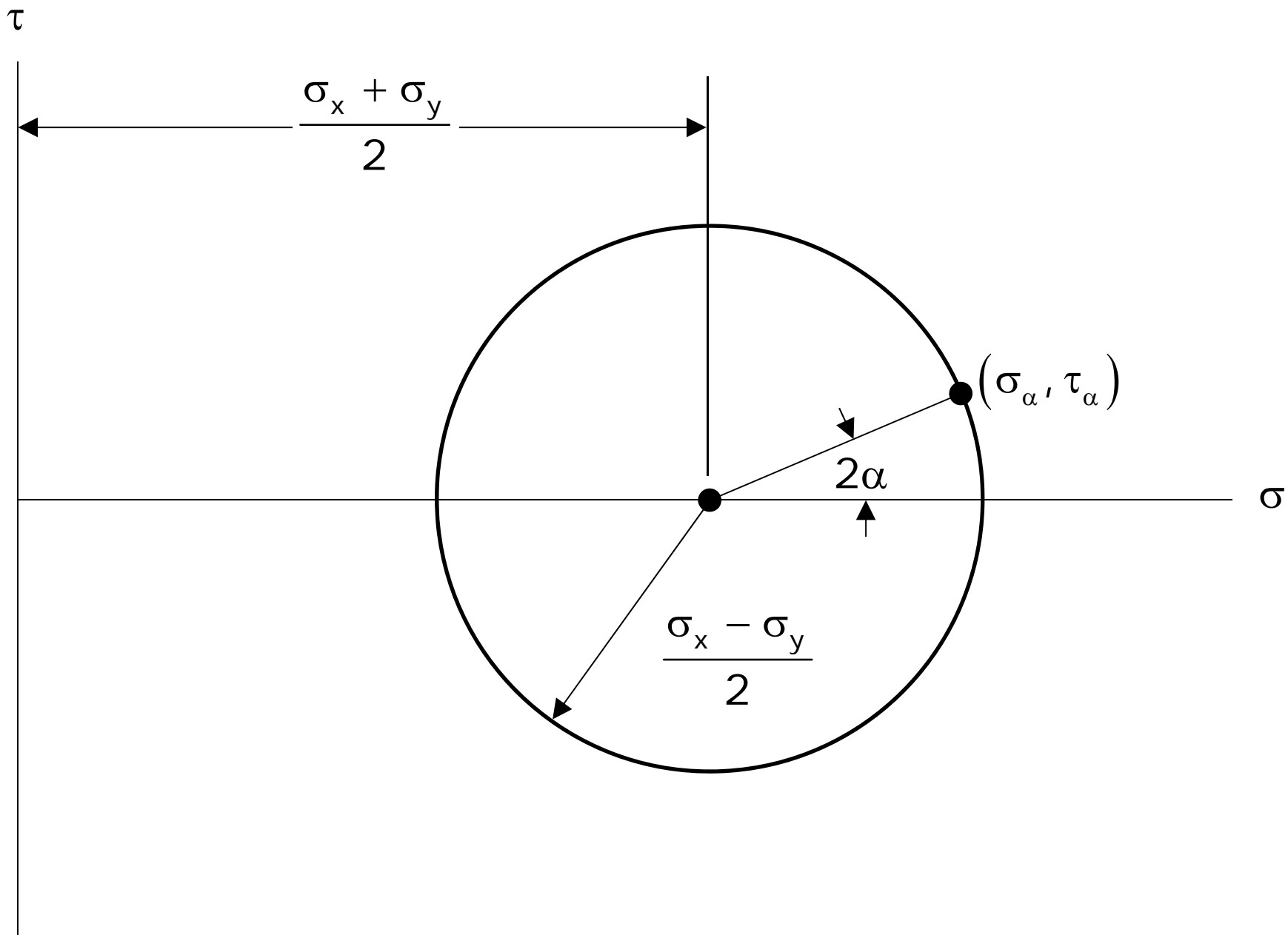

Mohr Circle Examples

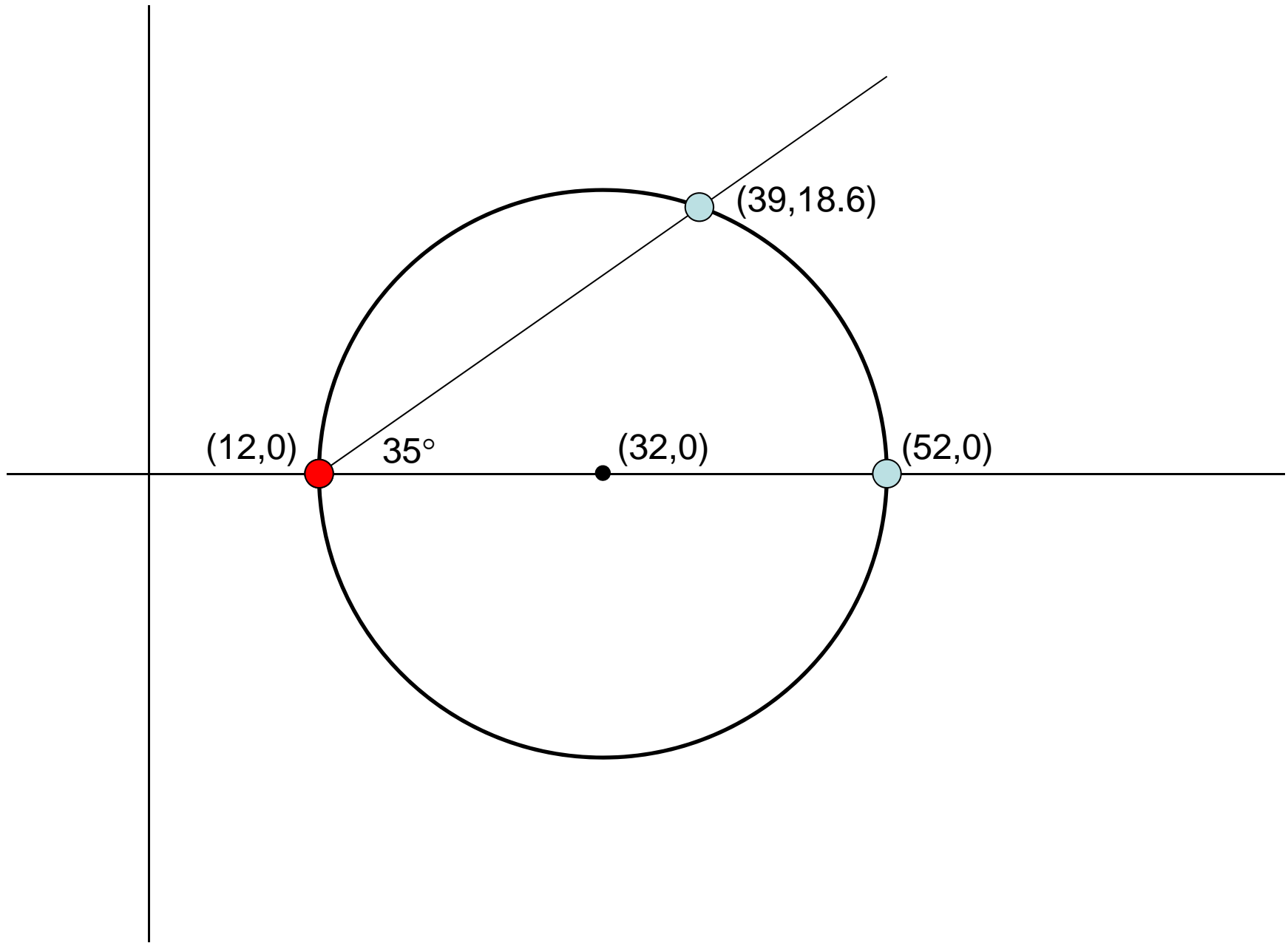

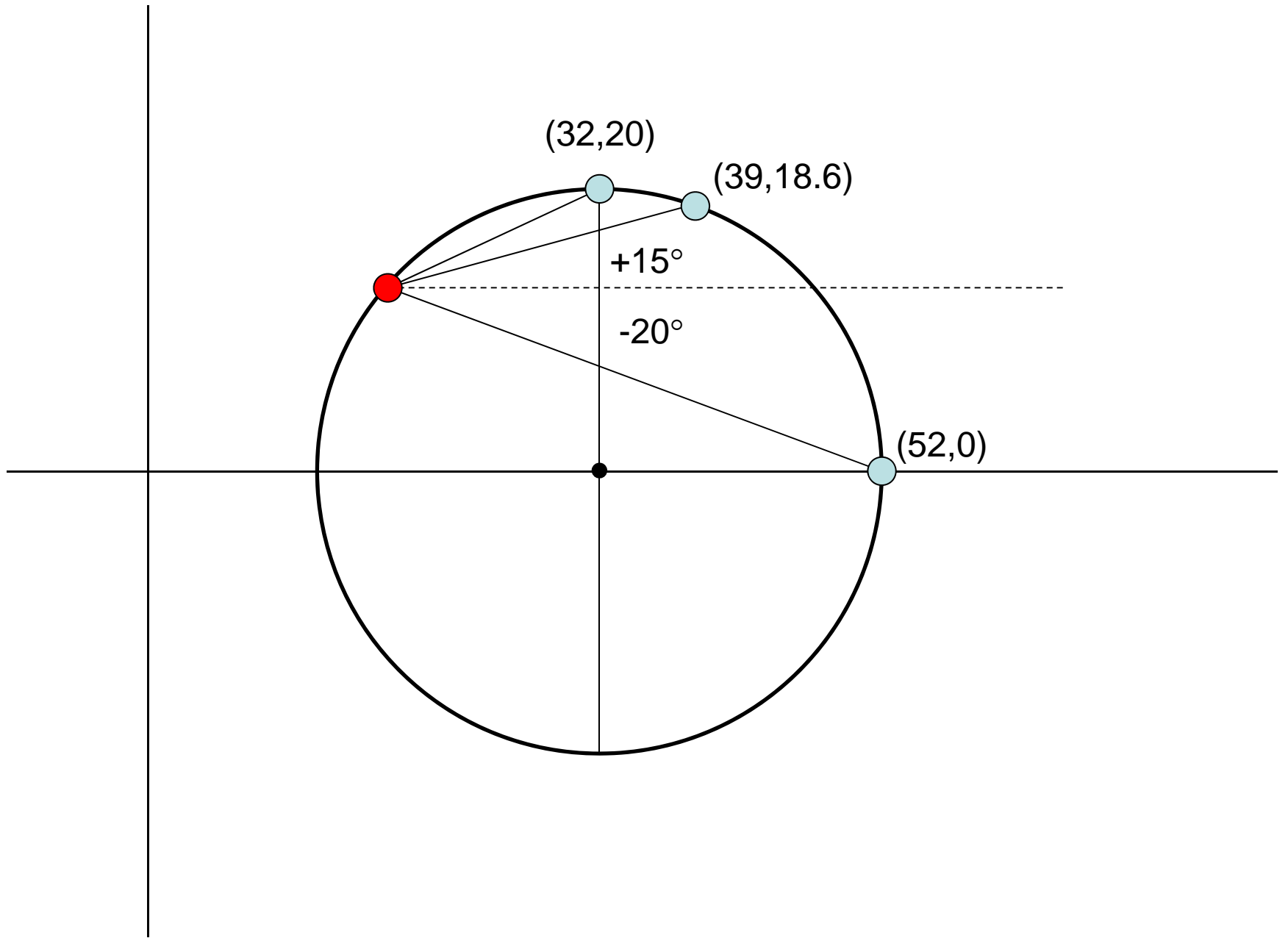

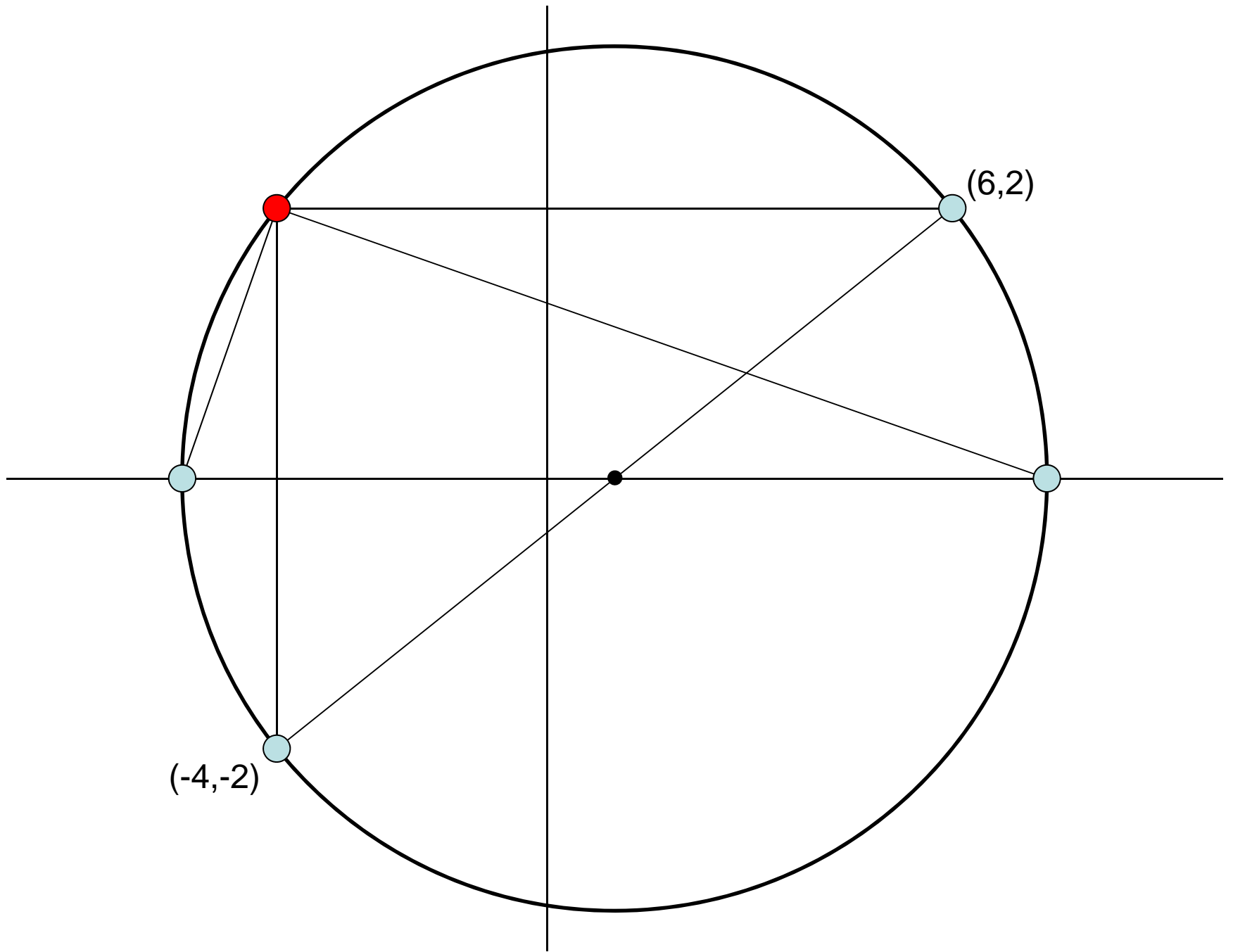

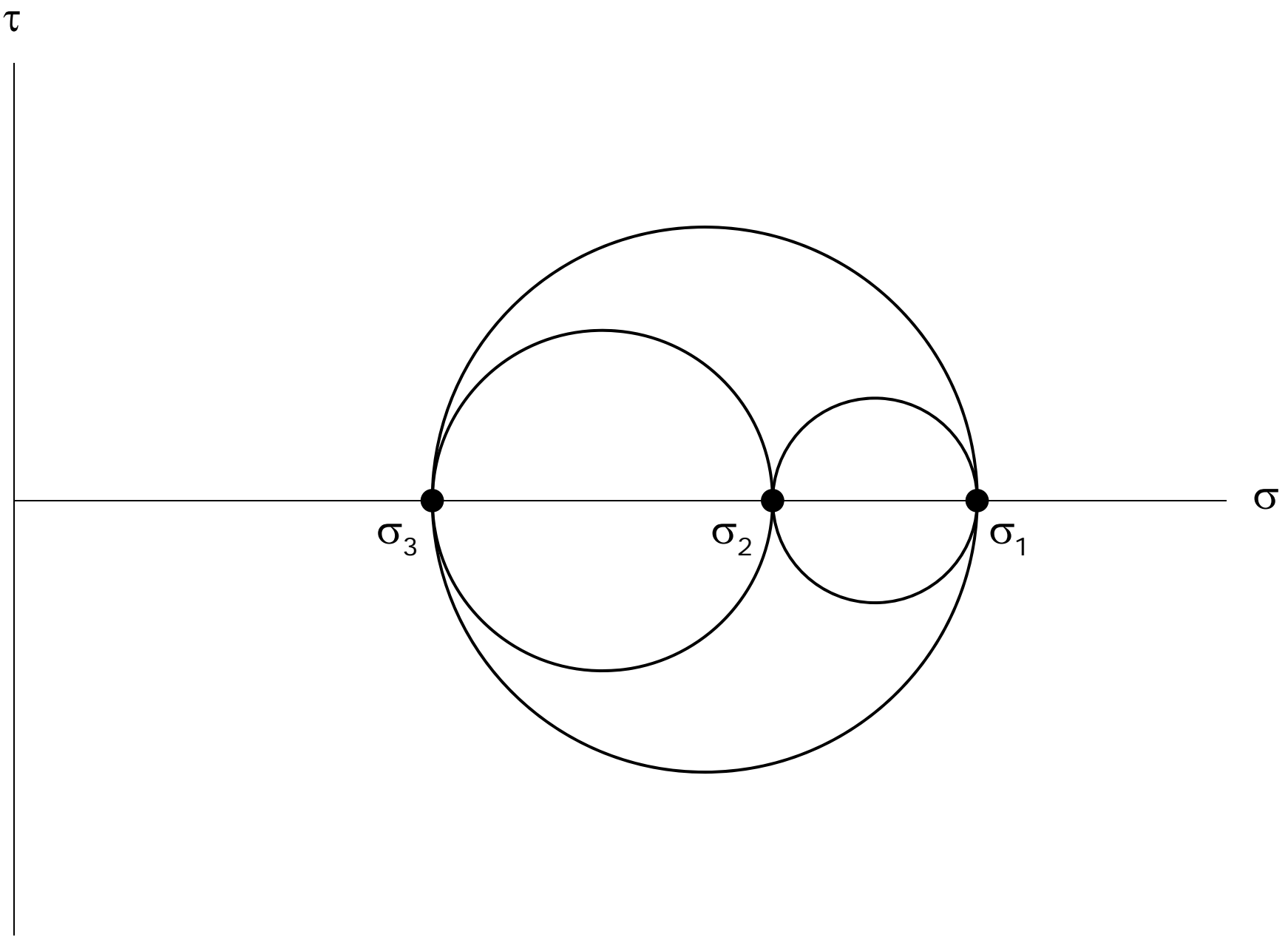

Mohr-Coulomb

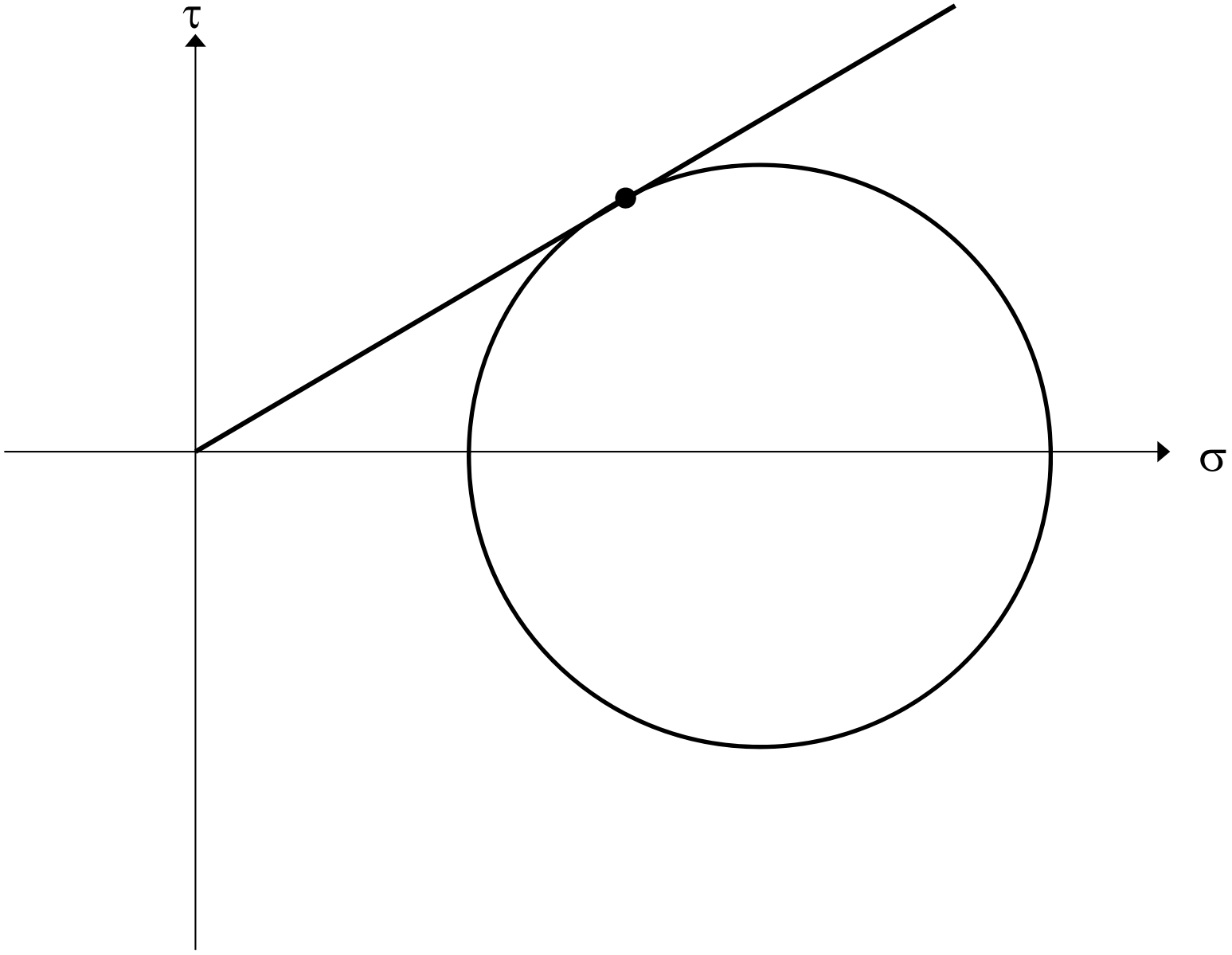

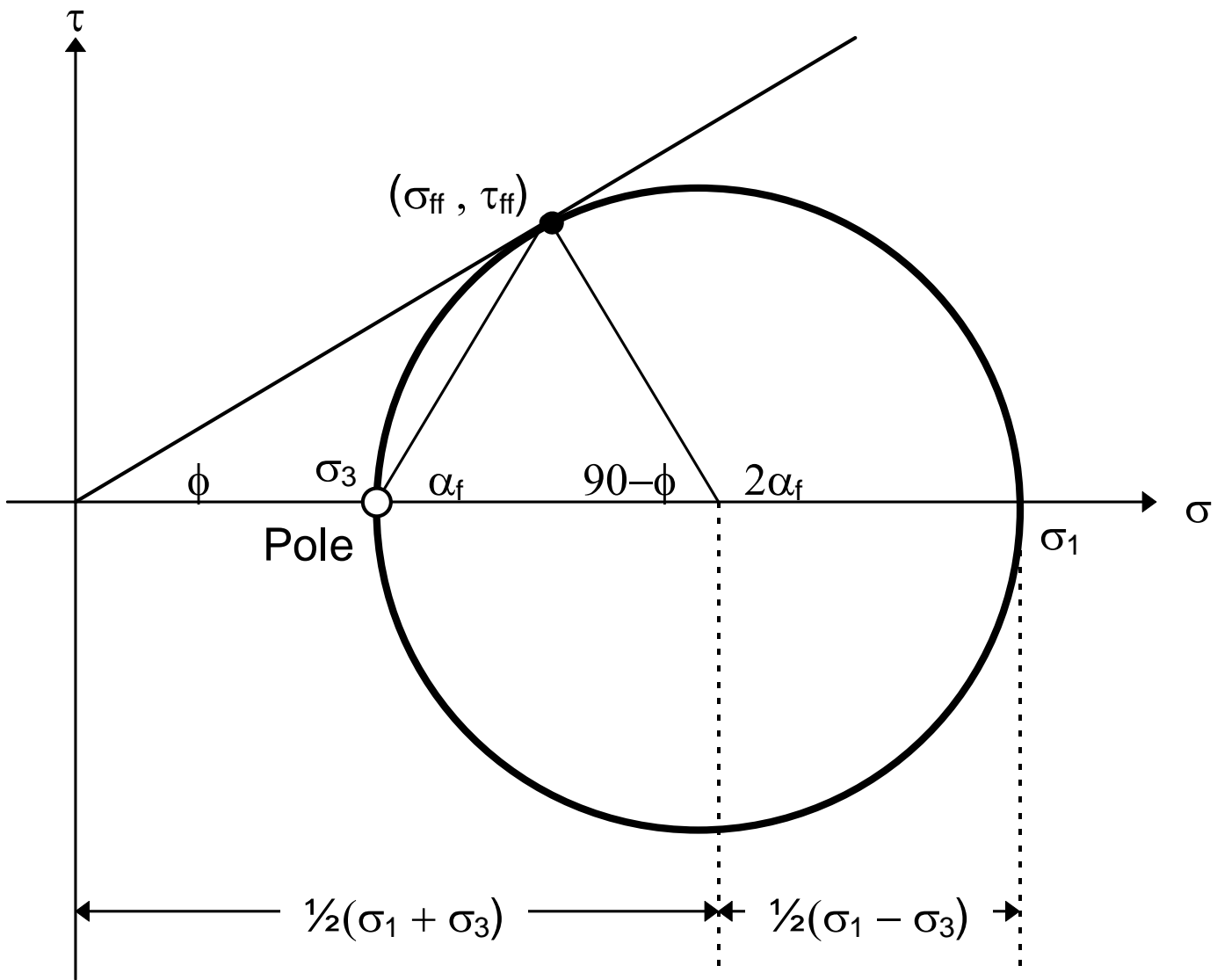

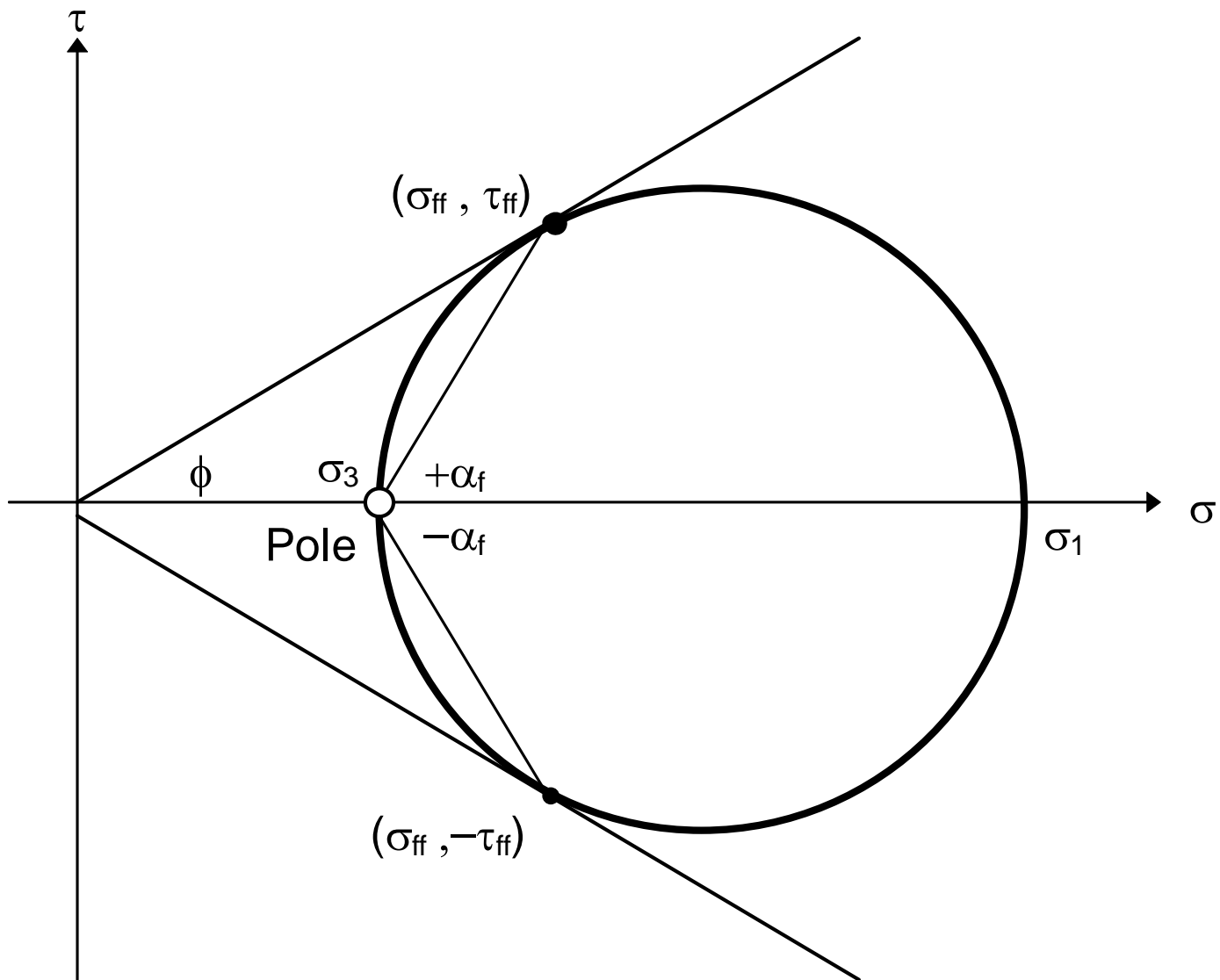

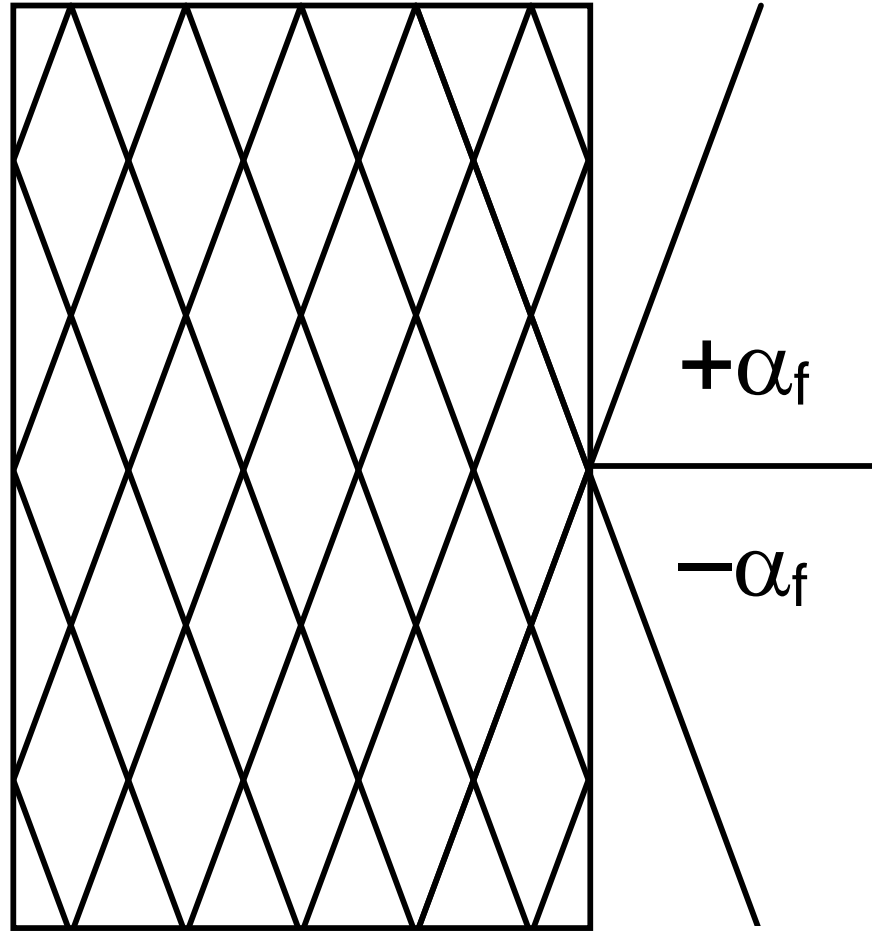

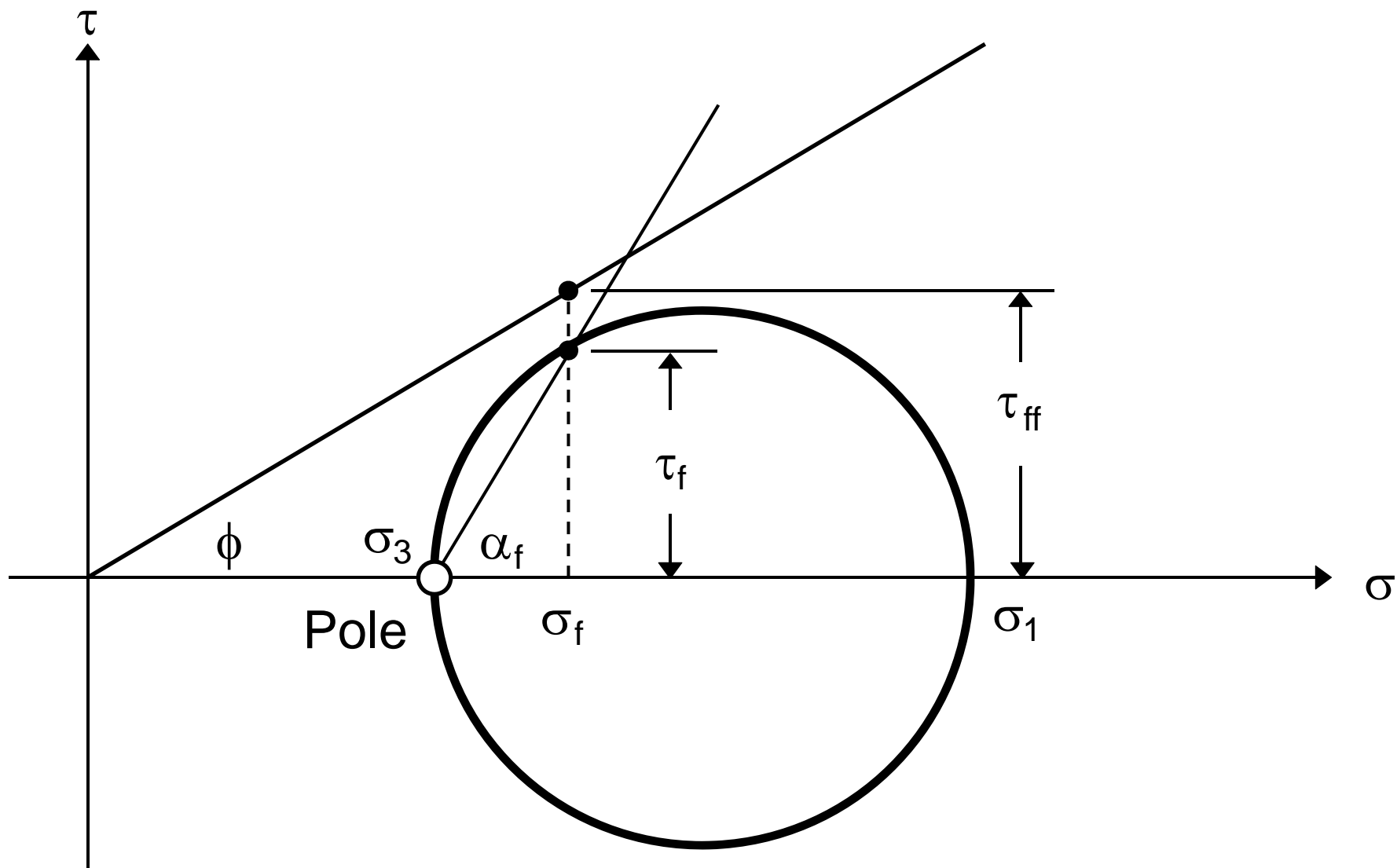

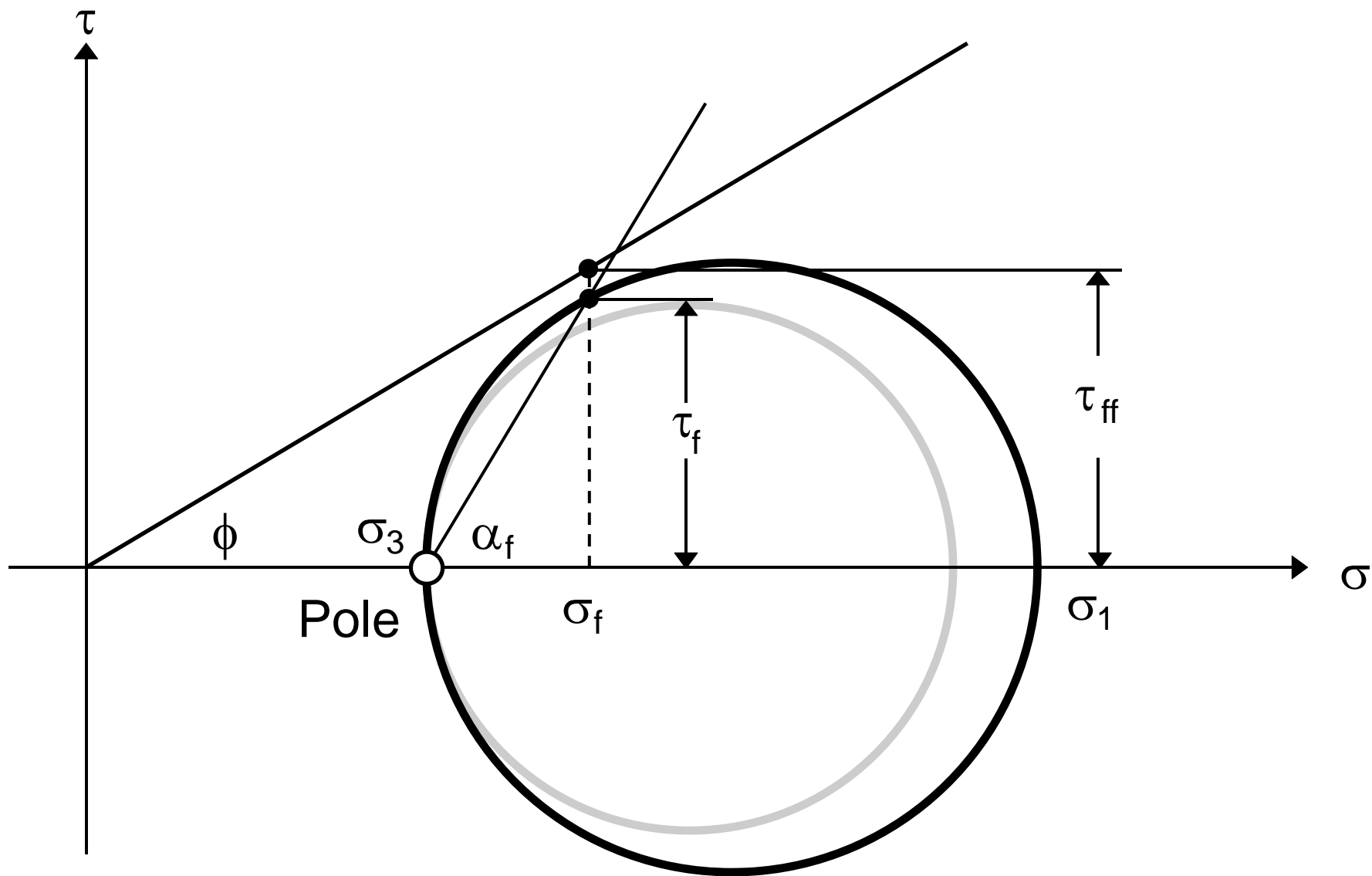

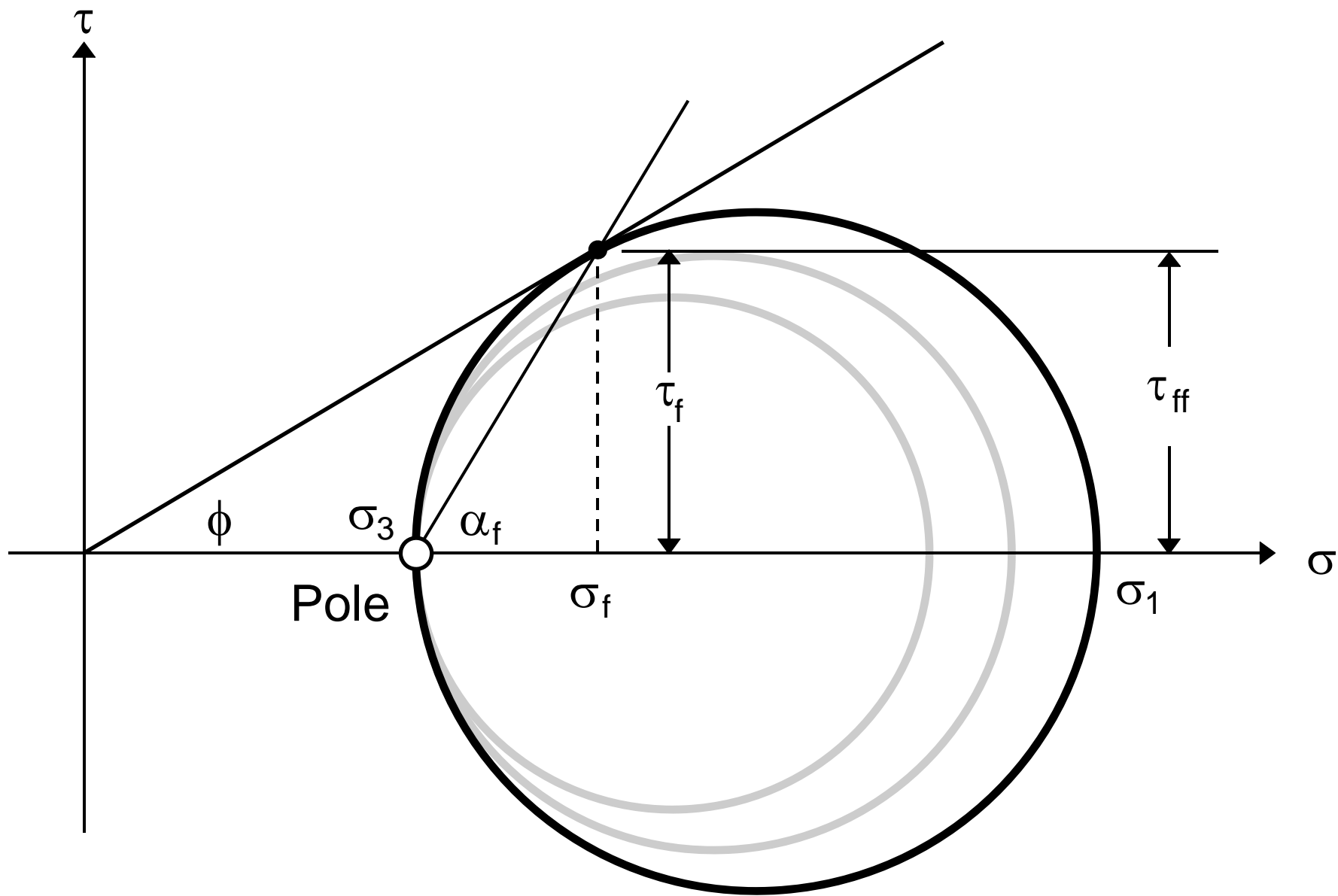

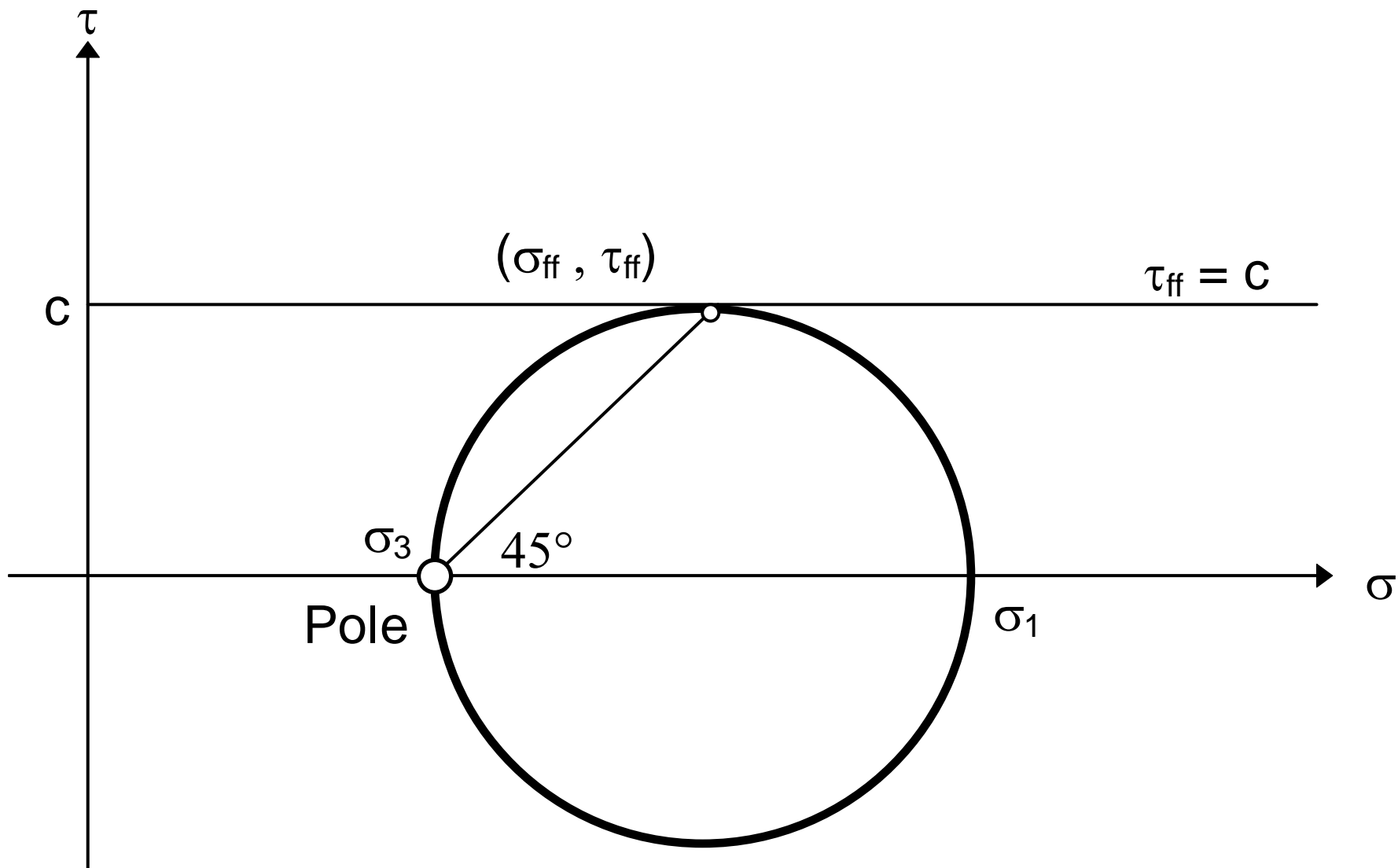

Obliquity Relationships

Cohesive Soil

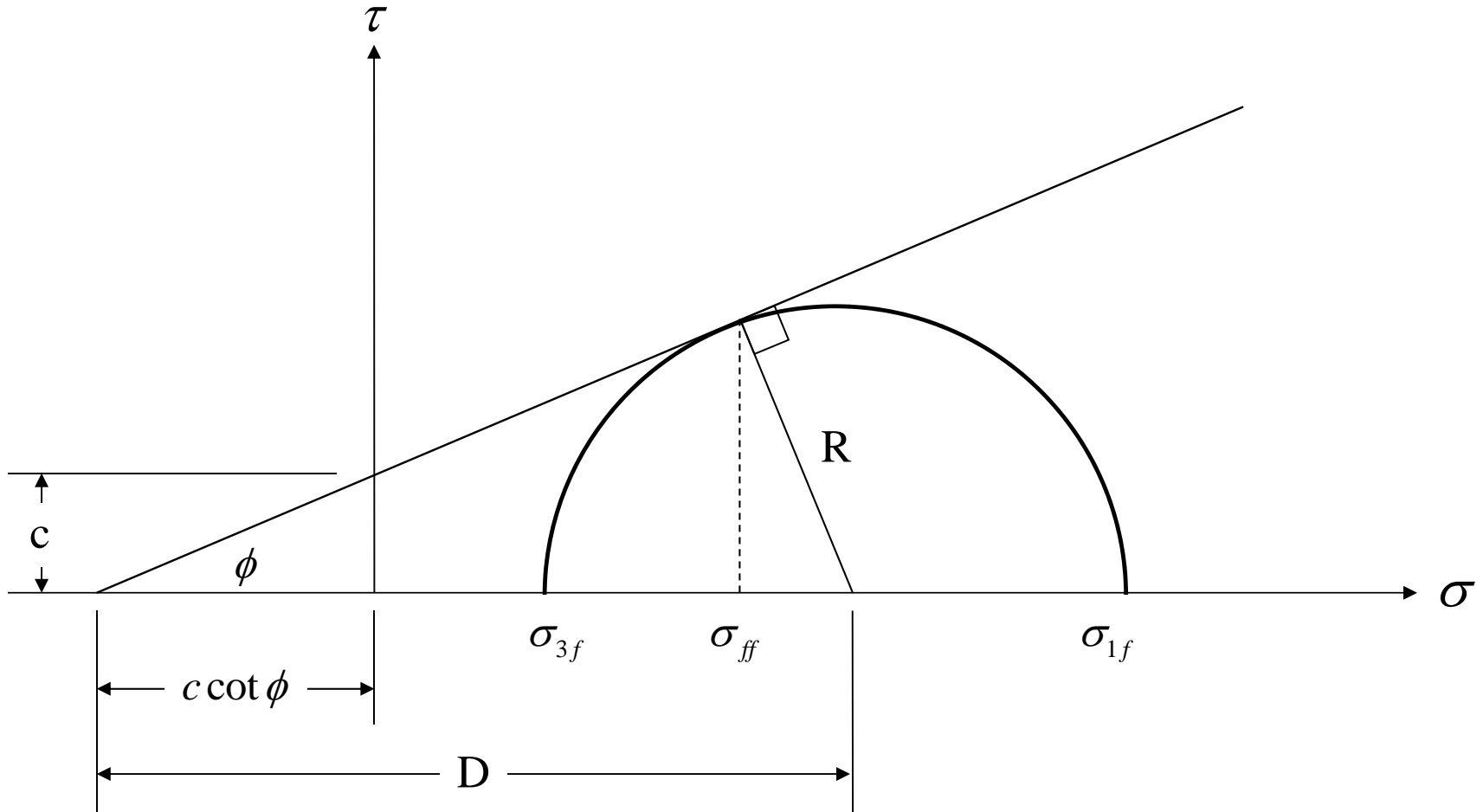

Cohesive Soil

$$\sin \phi = \frac{R}{D} = \frac{\frac{1}{2}(\sigma_{1f} - \sigma_{3f})}{\frac{1}{2}(\sigma_{1f} + \sigma_{3f}) + c \cot \phi} = \frac{(\sigma_{1f} - \sigma_{3f})}{(\sigma_{1f} + \sigma_{3f}) + 2c \cot \phi}$$

Cohesionless Soil

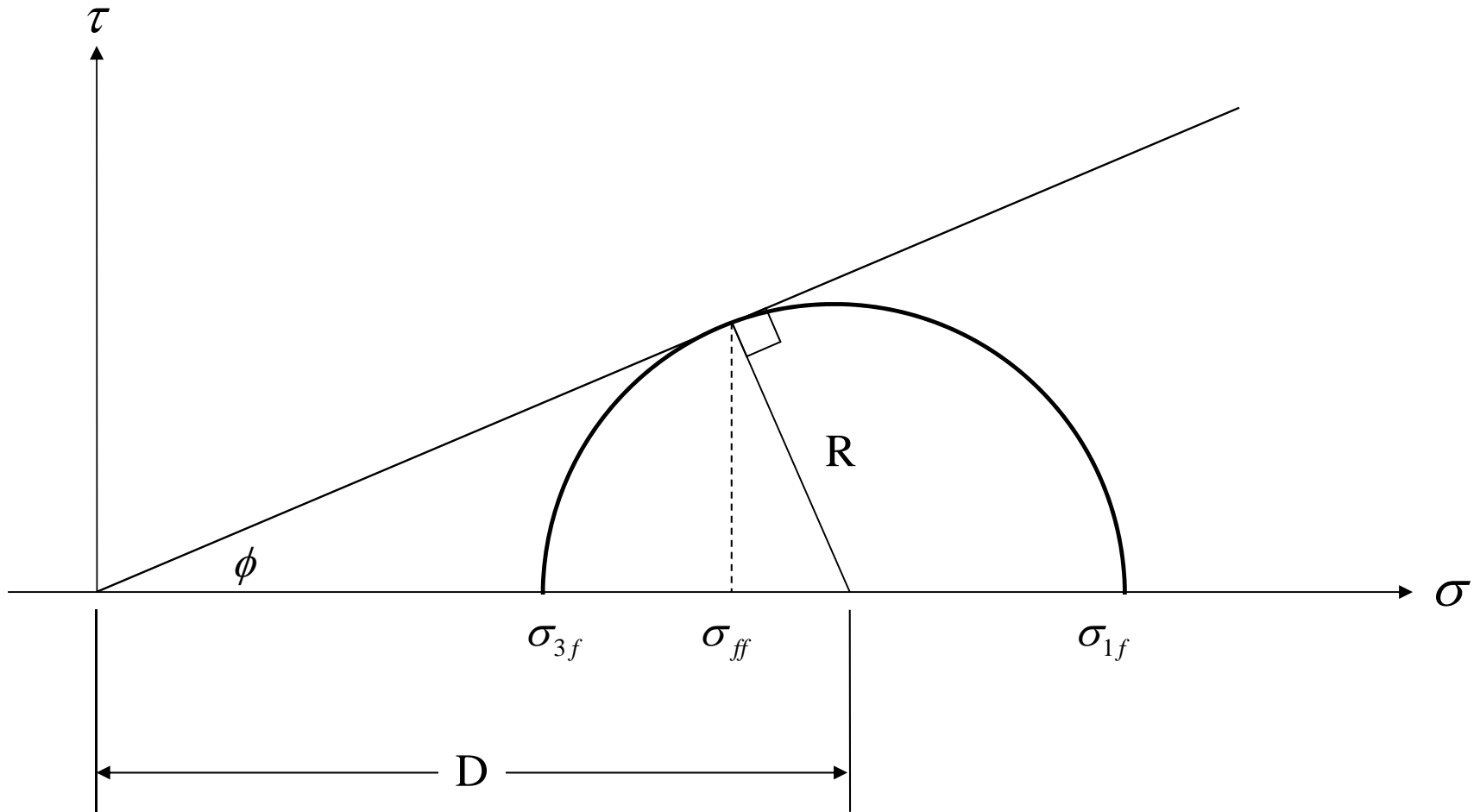

Cohesionless Soil

$$\sin \phi = \frac{R}{D} = \frac{\frac{1}{2}(\sigma_{1f} - \sigma_{3f})}{\frac{1}{2}(\sigma_{1f} + \sigma_{3f})} = \frac{(\sigma_{1f} - \sigma_{3f})}{(\sigma_{1f} + \sigma_{3f})}$$

Obliquity Relationships

$$\frac{\sigma_{1f}}{\sigma_{3f}} = \frac{(1 + \sin \phi)}{(1 - \sin \phi)} = \tan^2 \left(45^\circ + \frac{\phi}{2} \right)$$

$$\frac{\sigma_{3f}}{\sigma_{1f}} = \frac{(1 - \sin \phi)}{(1 + \sin \phi)} = \tan^2 \left(45^\circ - \frac{\phi}{2} \right)$$

Angle of Obliquity

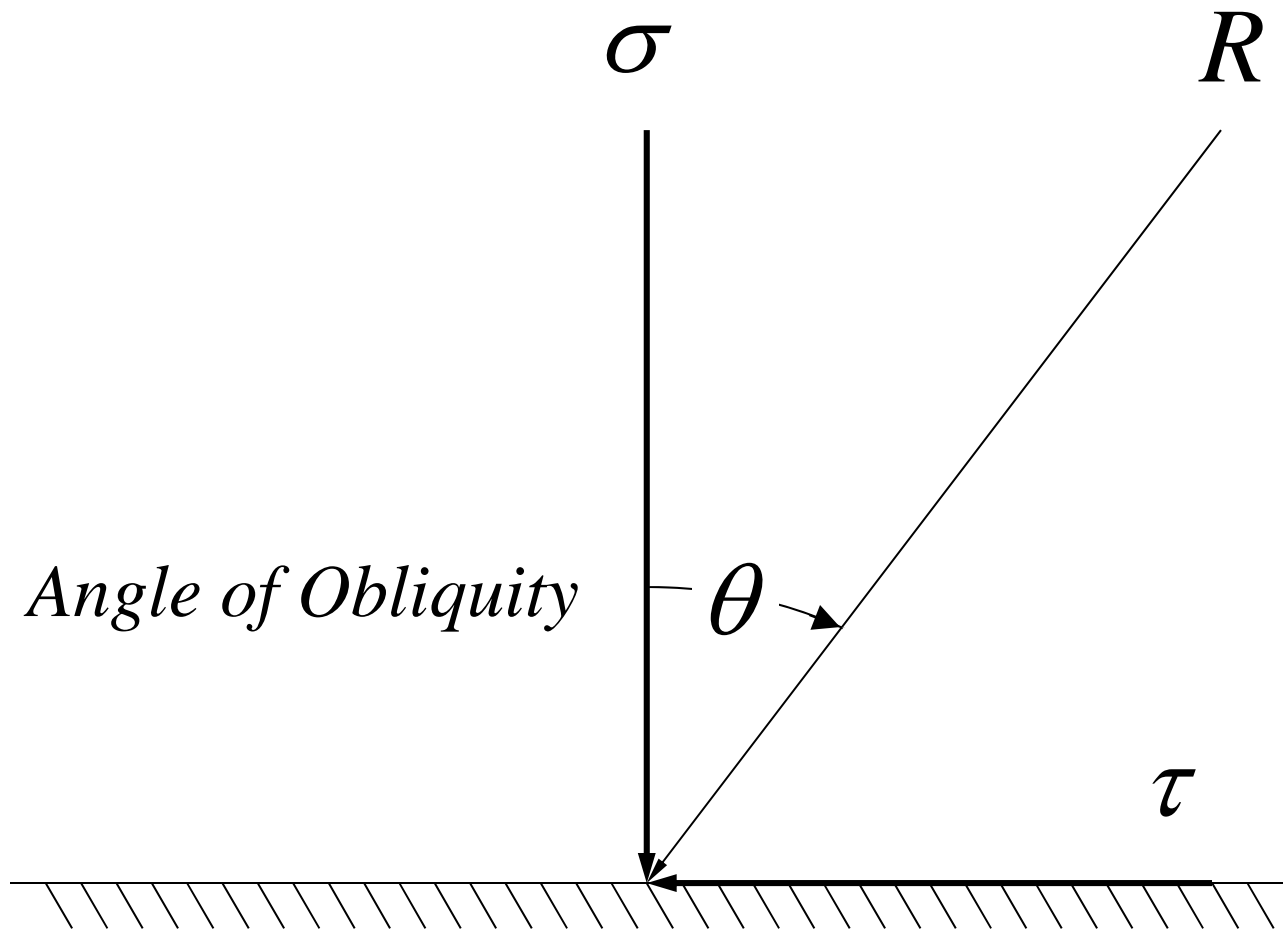

Example

- A conventional triaxial compression test is conducted on a medium-dense sandy silt with $\phi = 32^\circ$.
- If the cell pressure (σ_3) is 40 kPa, what is the major principal stress at failure?
- What is the normal stress on the failure plane at failure?

$$\sigma_{1f} = \sigma_{3f} \tan^2 \left(45^\circ + \frac{\phi}{2} \right) = 40 \tan^2 (61^\circ) = 130 \text{ kPa}$$

Cohesionless Soil

