

Settlement Analysis

Settlement Analysis

1. Determine the initial conditions
2. Determine the geometry and magnitude of the applied loads
3. Estimate the change in stress within the compressible layers
4. Estimate the preconsolidation pressure
5. Calculate the consolidation settlement
6. Estimate the time rate of consolidation settlement
7. Estimate the magnitude and rate of secondary compression
8. Estimate the immediate or distortion settlement

Boussinesq Point Load

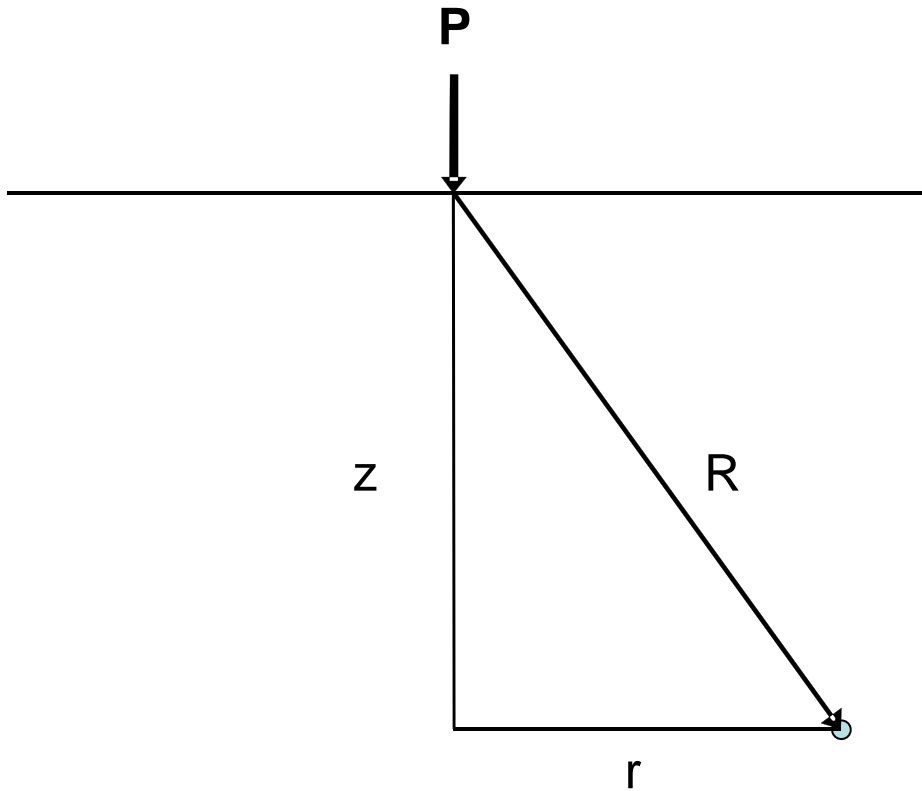

$$\sigma_z = \frac{P}{2\pi R^2} \left(\frac{z^3}{R^3} \right)$$

Boussinesq Point Load

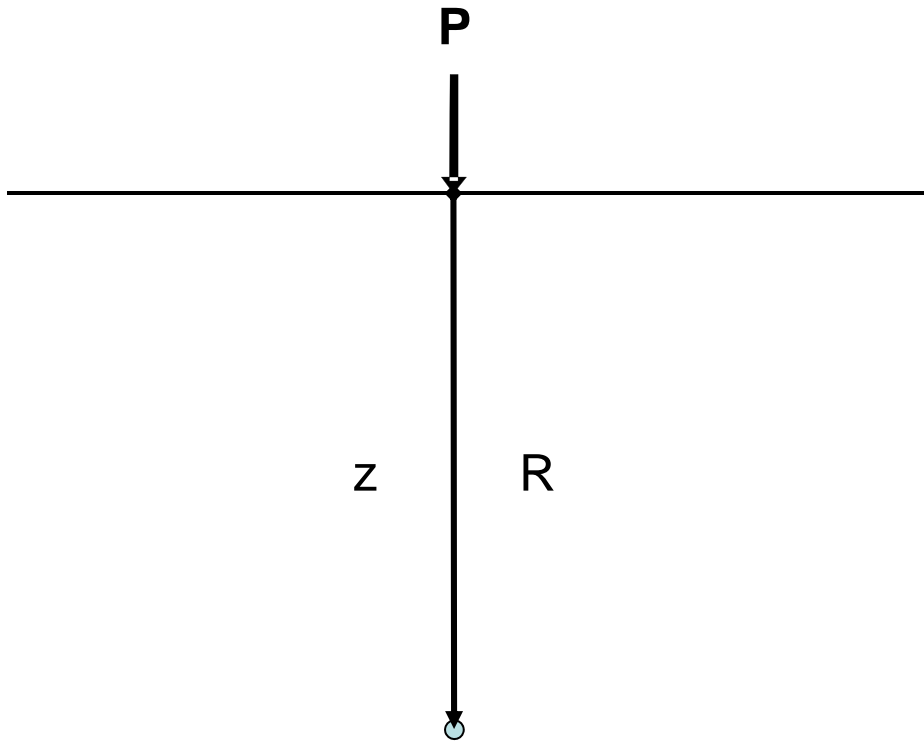

$$\sigma_z(r=0) = \frac{P}{2\pi z^2}$$

Rectangular Footing (2:1)

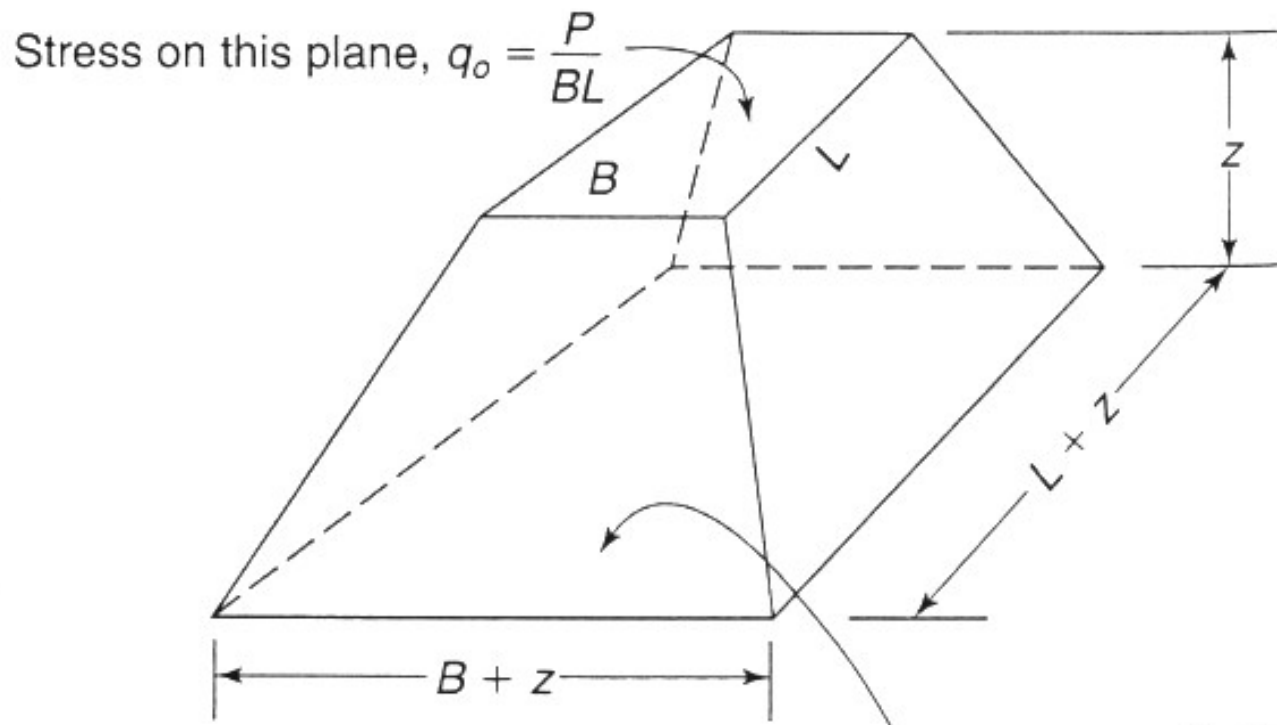

$$\text{Stress on this plane, } \sigma_z = \frac{P}{(B+z)(L+z)}$$

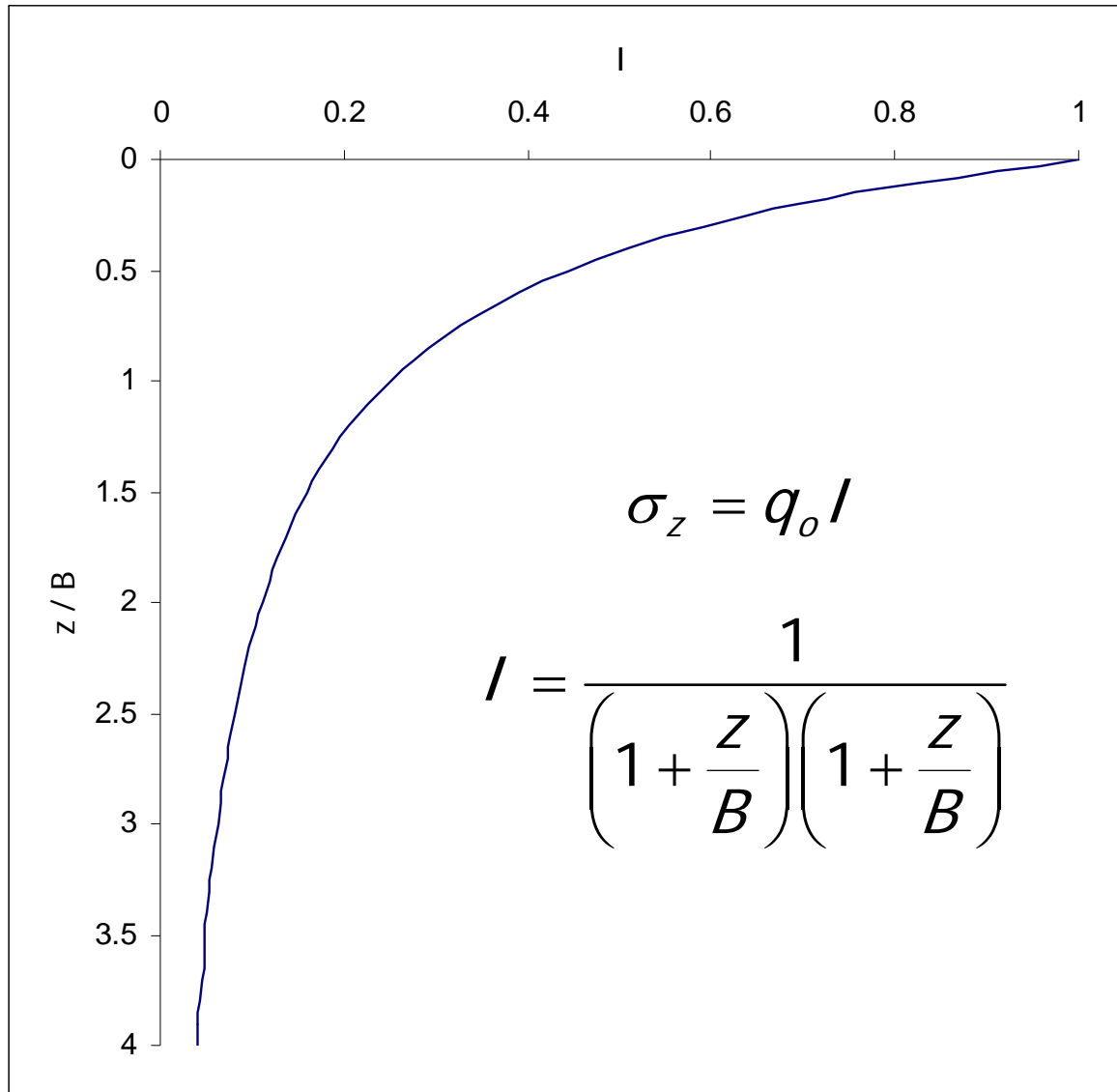

Boussinesq Line Load

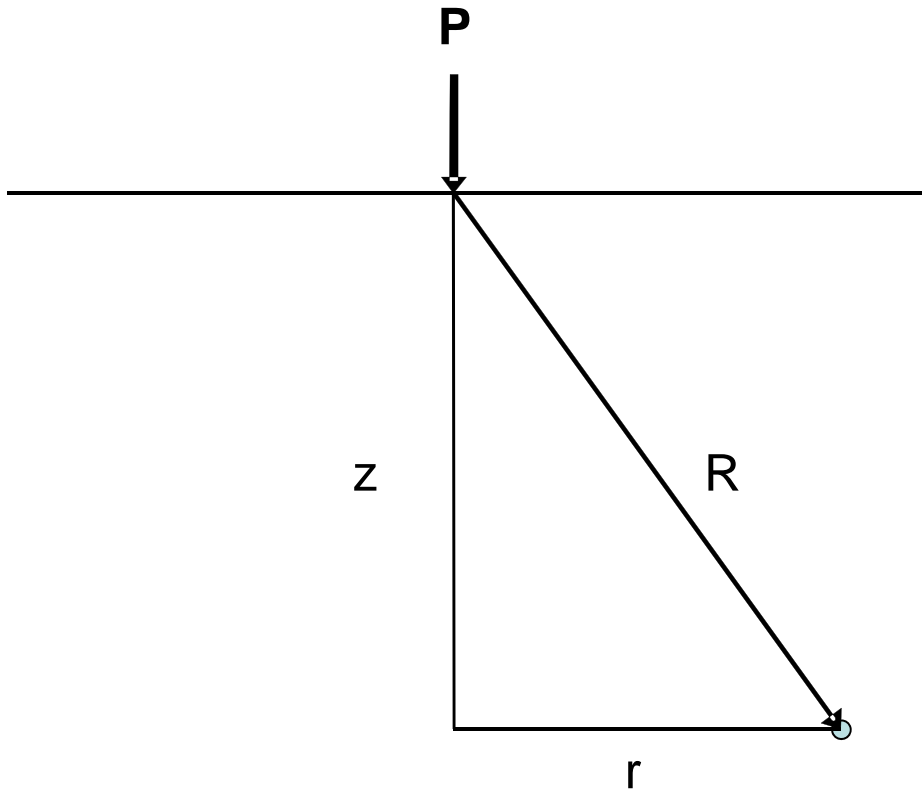

$$\sigma_z = \frac{2P}{\pi} \left(\frac{z^3}{R^4} \right)$$

Strip Footing (2:1)

Stress on this plane, $q_o = \frac{P}{B}$ P is a force per unit length

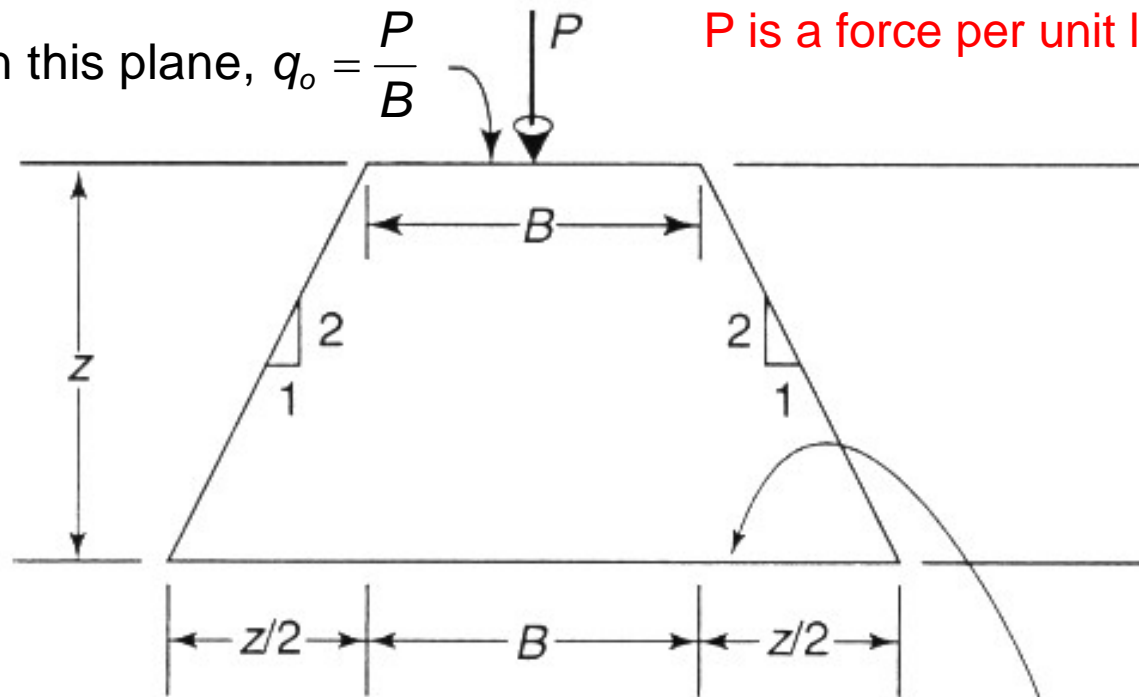

Stress on this plane, $\sigma_z = \frac{P}{(B + z)}$

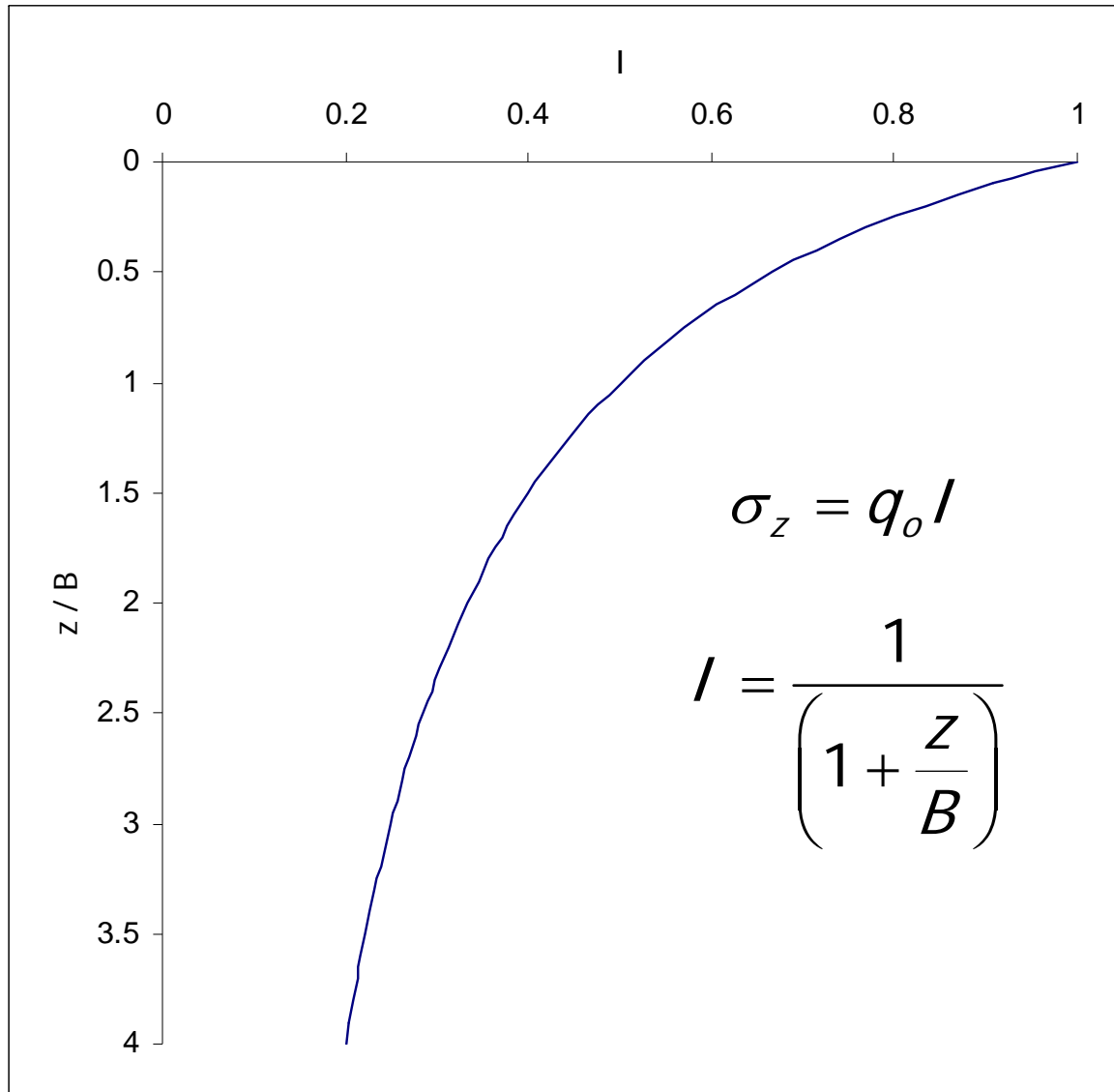

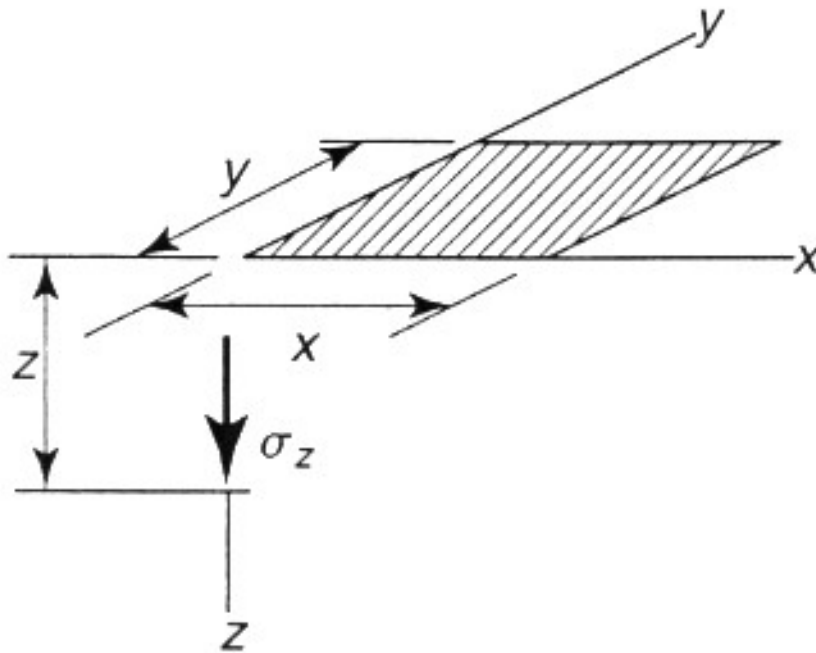

Load q_0 per unit area

$$m = \frac{x}{z}; n = \frac{y}{z}$$

$$\sigma_z = q_0 I$$

$$I = \frac{1}{2\pi} \left[\frac{mn}{\sqrt{m^2 + n^2 + 1}} \left(\frac{1}{m^2 + 1} + \frac{1}{n^2 + 1} \right) + \tan^{-1} \frac{mn}{\sqrt{m^2 + n^2 + 1}} \right]$$

Mistake in the textbook

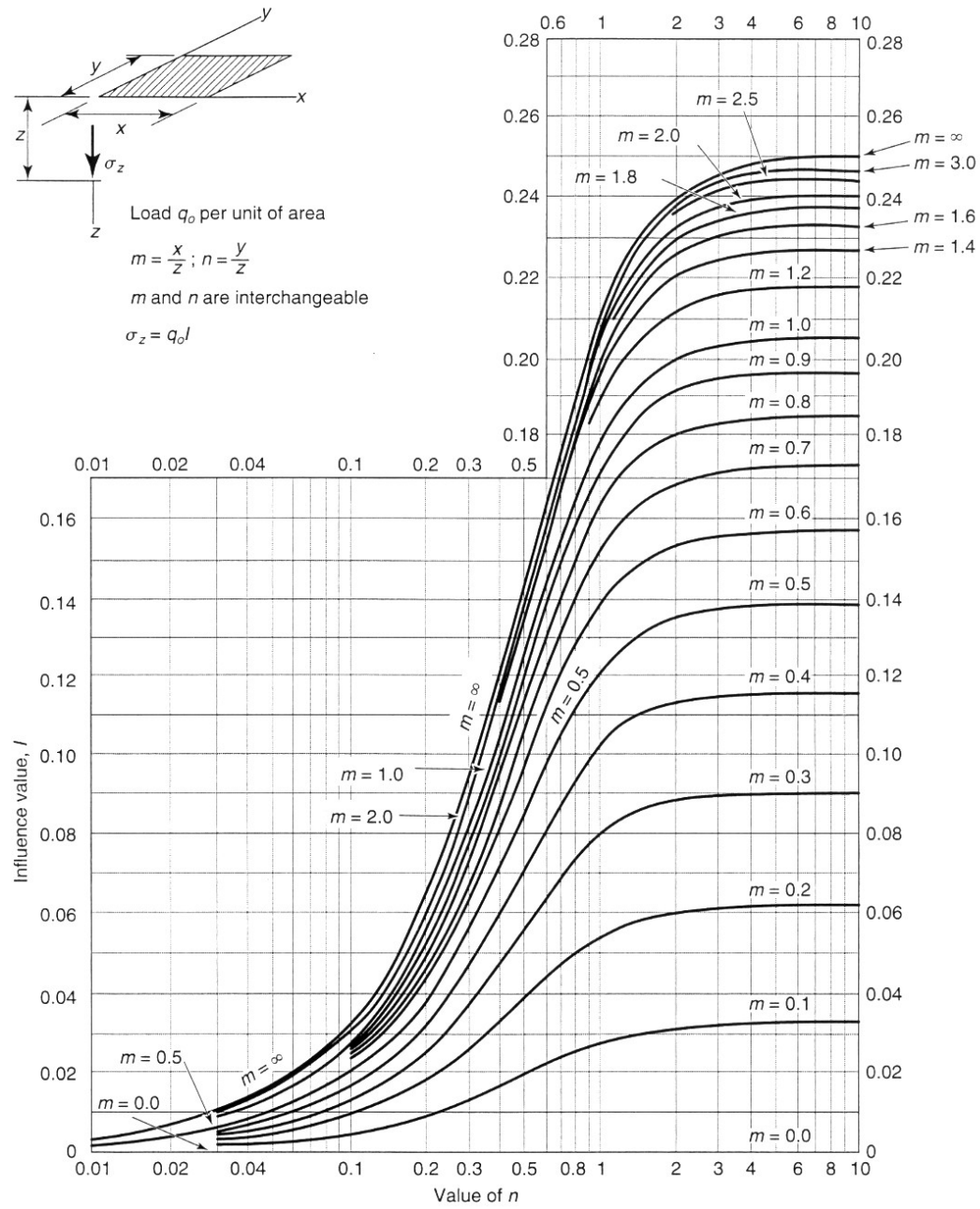

FIGURE 10.4 Influence value for vertical stress under corner of a uniformly loaded rectangular area (after Fadum, 1948).

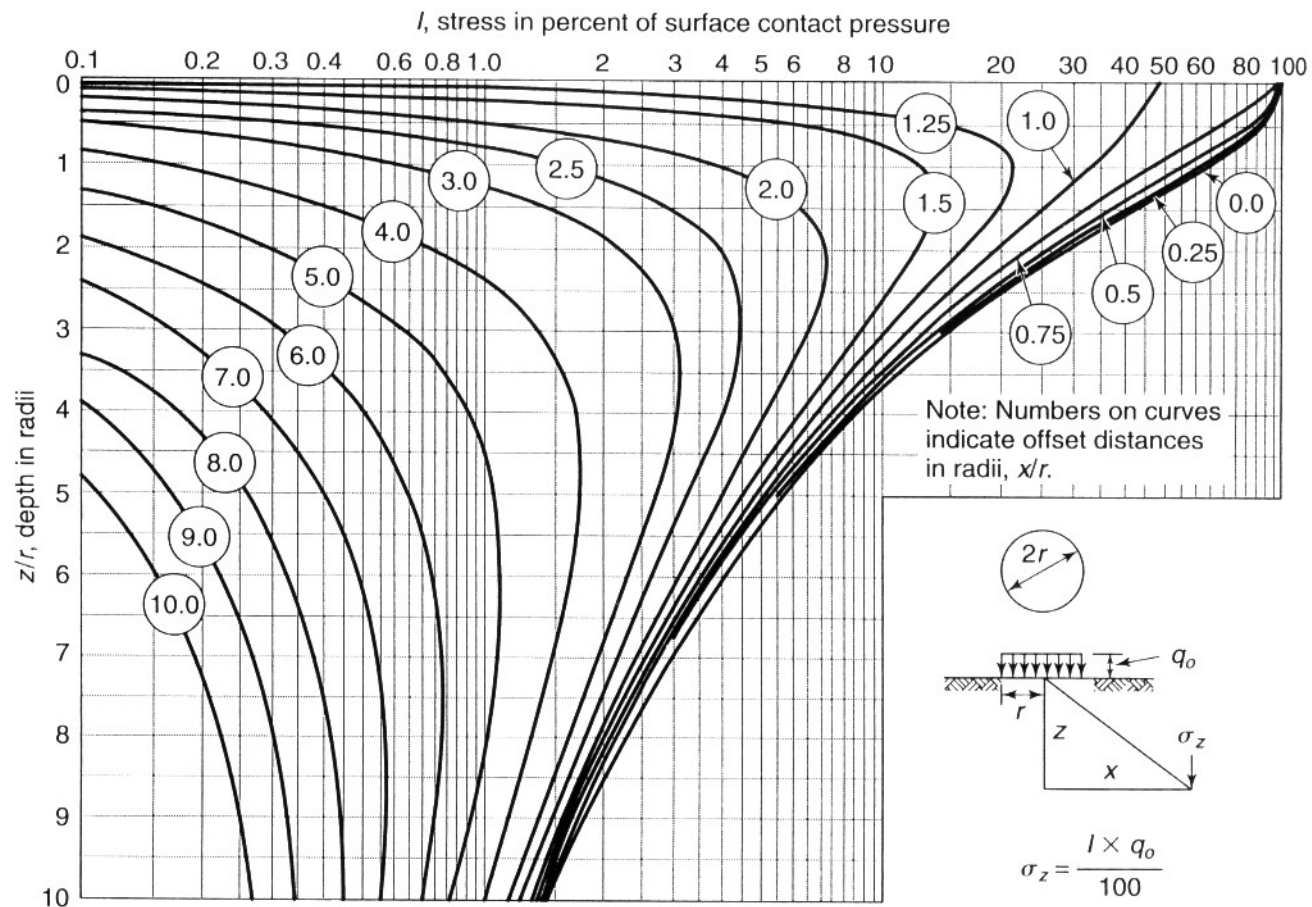

FIGURE 10.5 Influence values, expressed in percentage of surface contact pressure q_o , for vertical stress under uniformly loaded circular area (after Foster and Alvin, 1954, and U.S. Navy, 1986).

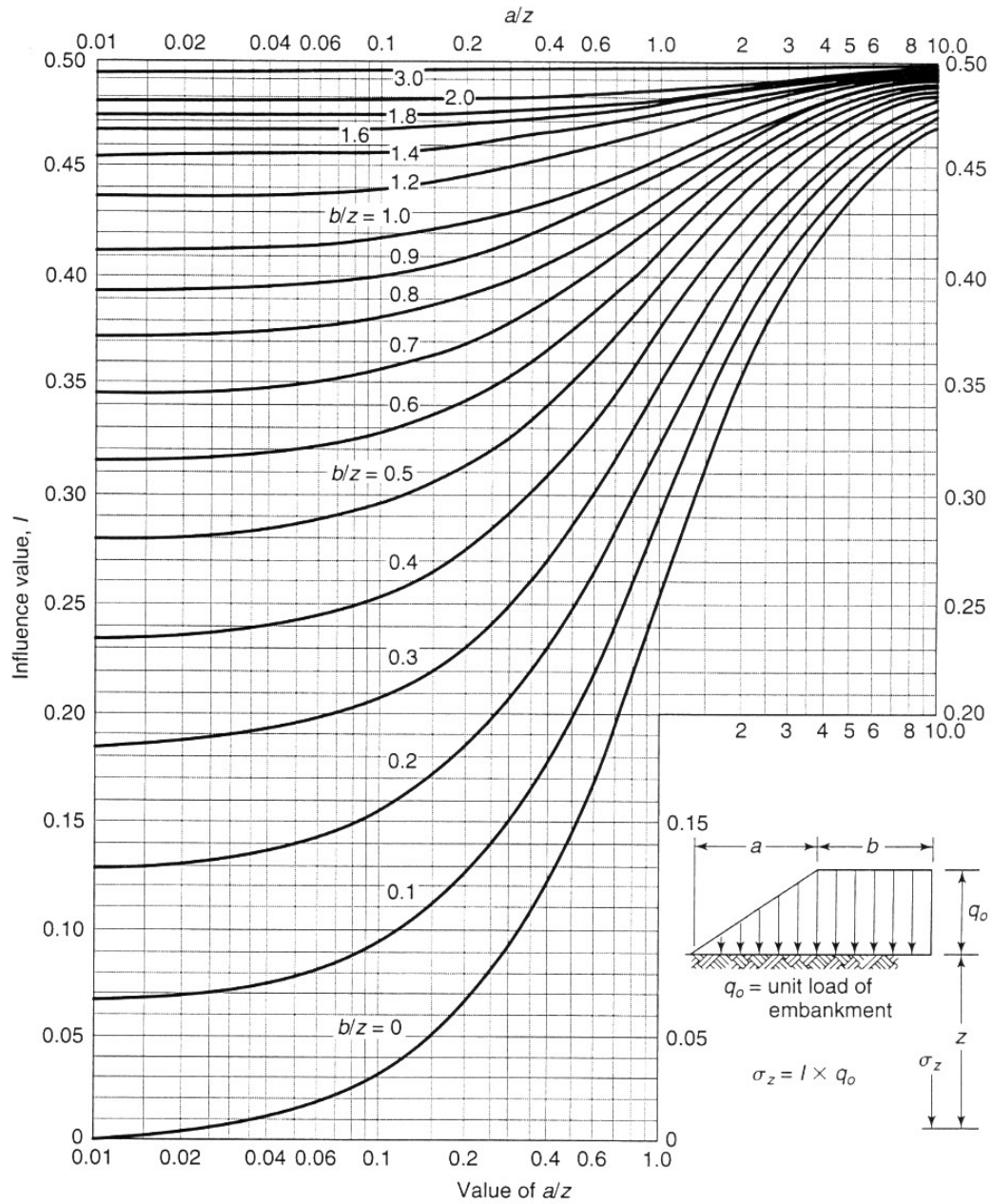
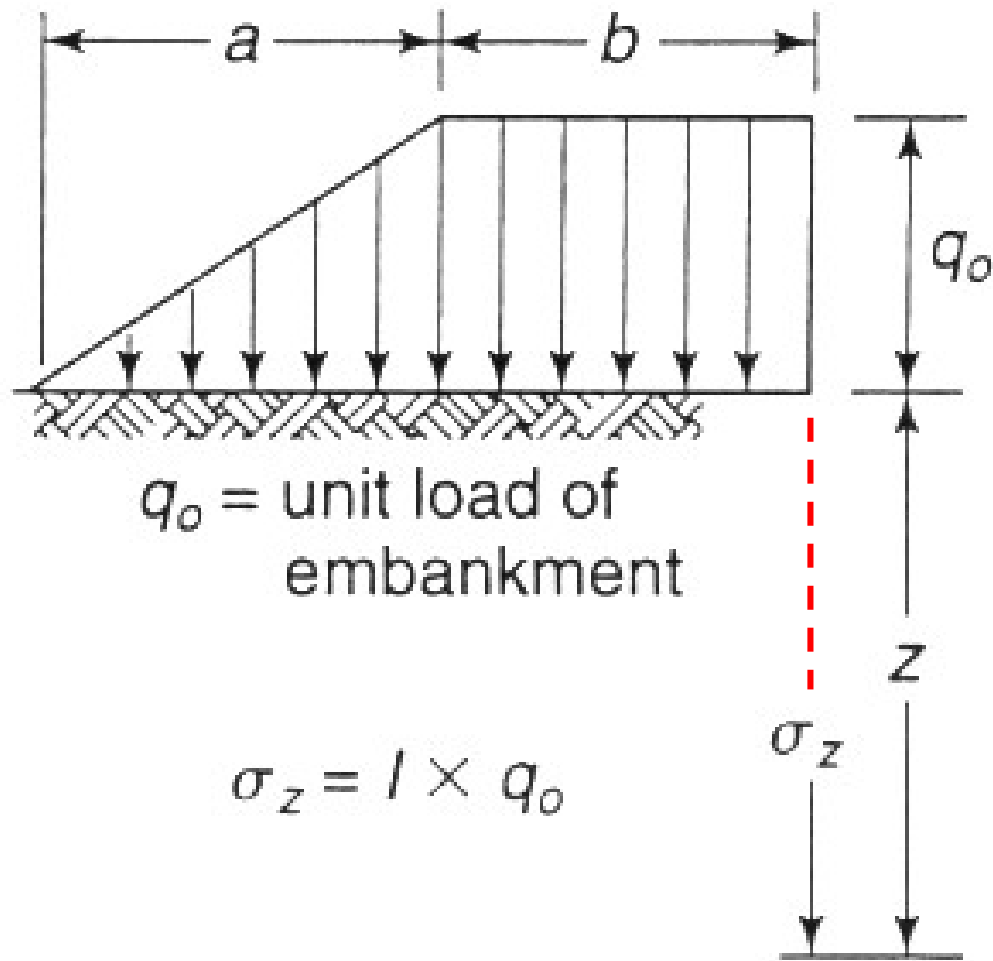
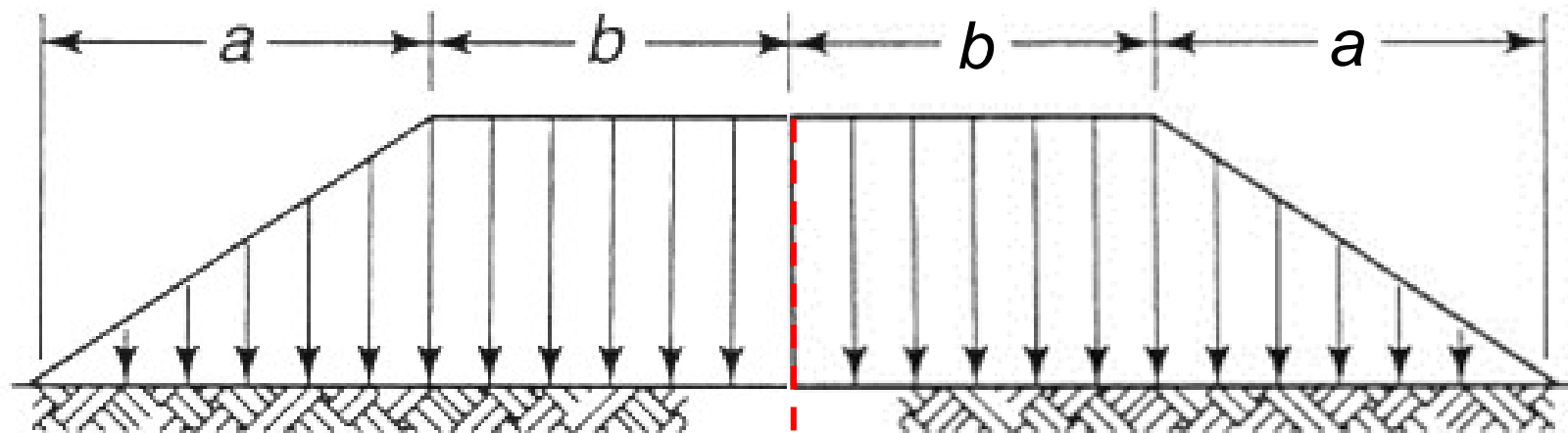

FIGURE 10.6 Influence values for vertical stress under a very long embankment; length = ∞ (from U.S. Navy, 1986, after Osterberg, 1957).





$q_0 = \text{unit load of embankment}$

$$\sigma_z = l \times q_0$$

σ_z

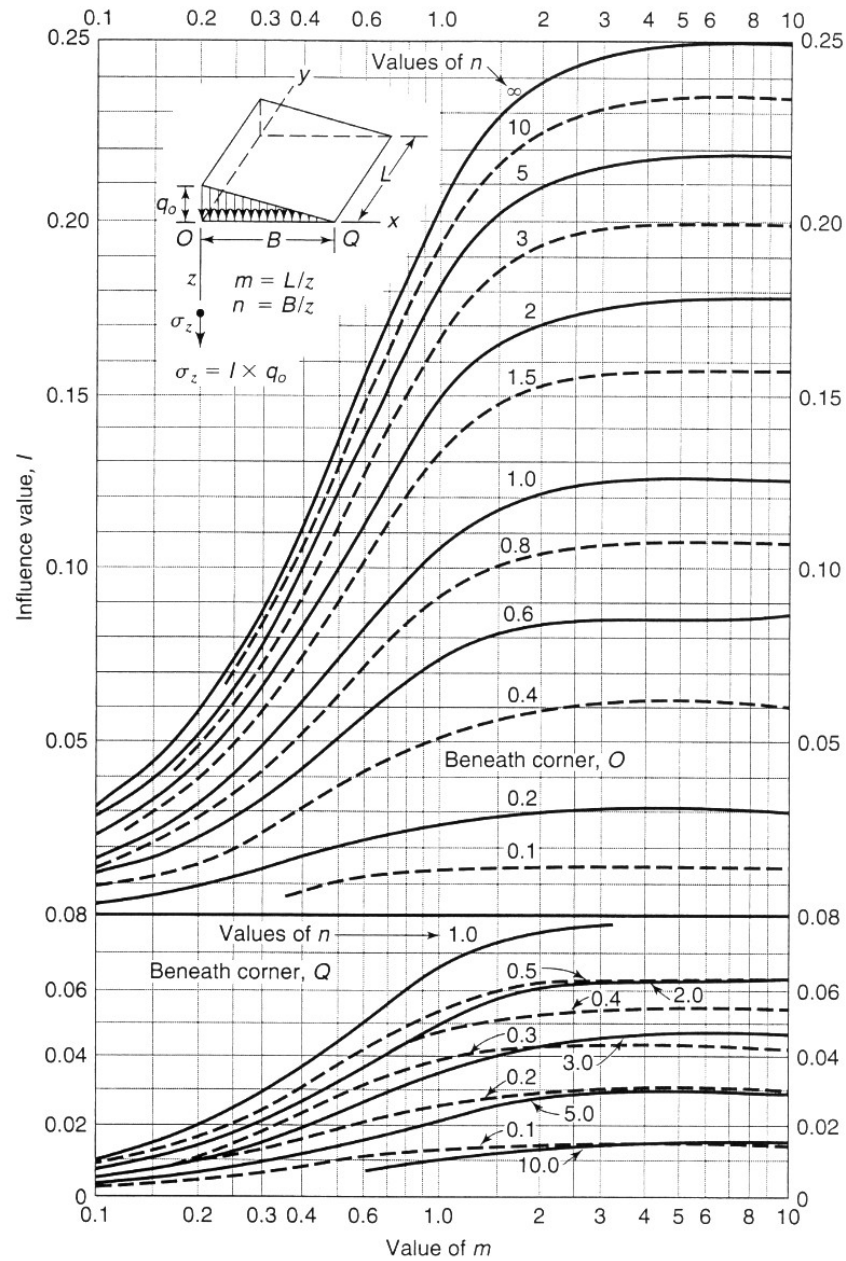

FIGURE 10.7 Influence values for vertical stress under the corners of a triangular load of limited length (after U.S. Navy, 1986).

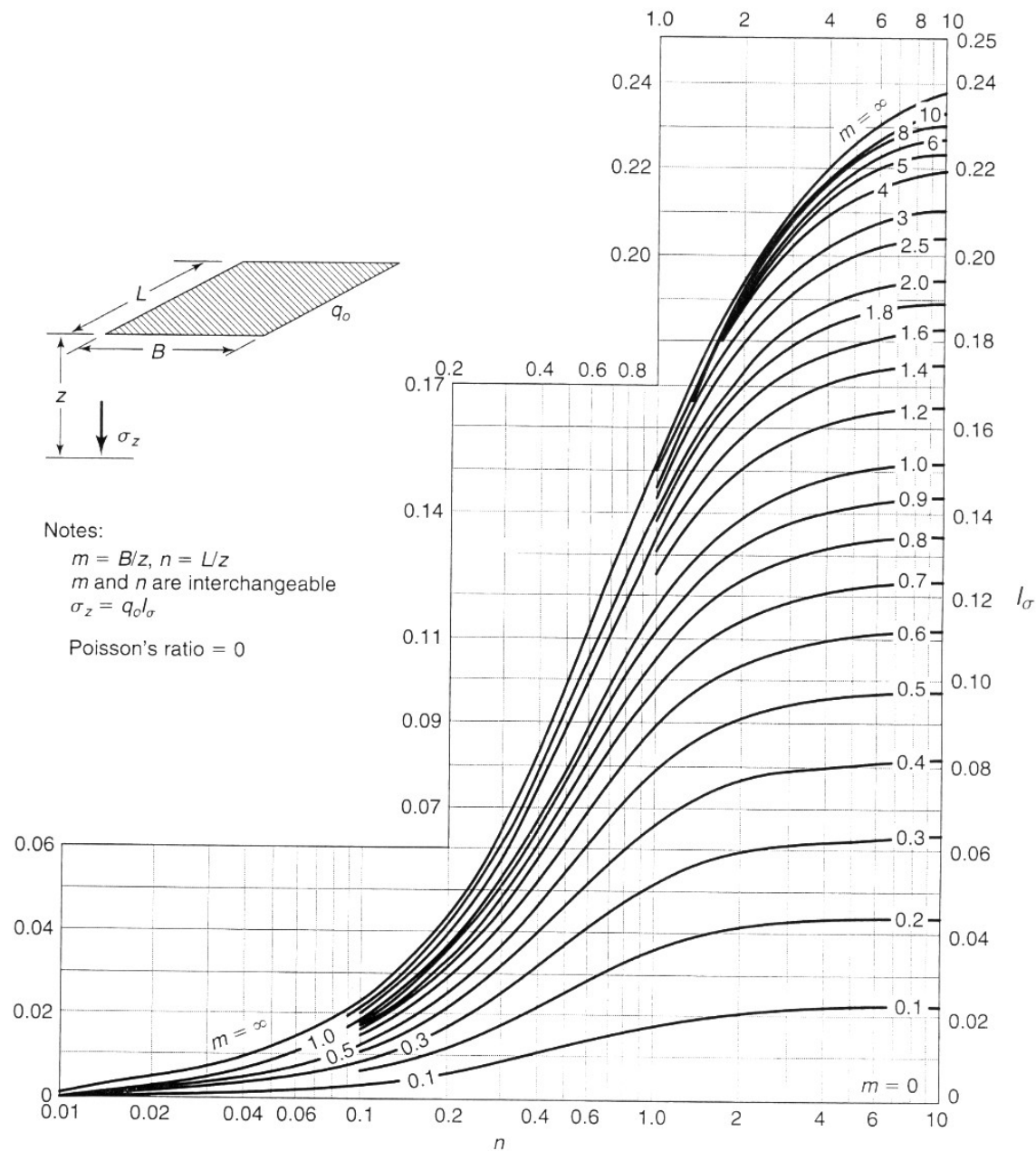
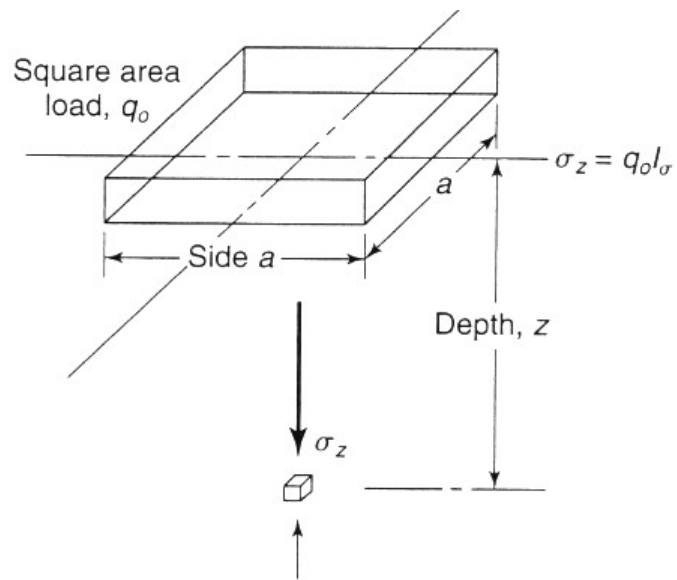
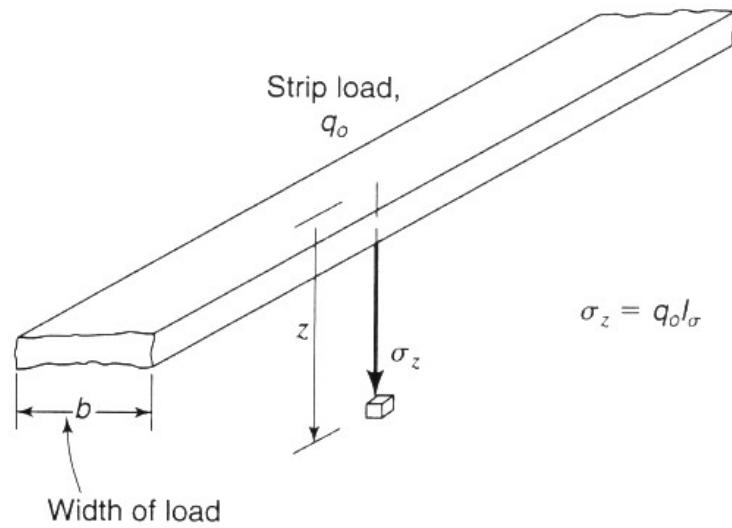

FIGURE 10.9 Influence values for vertical stress under corners of a uniformly loaded rectangular area for the Westergaard theory (after Duncan and Buchignani, 1976).



a/z	I_σ	
	Boussinesq	Westergaard
∞	1.0000	1.0000
20	0.9992	0.9365
16	0.9984	0.9199
12	0.9968	0.8944
10	0.9944	0.8734
8	0.9892	0.8435
6	0.9756	0.7926
5	0.9604	0.7525
4	0.9300	0.6971
3.6	0.9096	0.6659
3.2	0.8812	0.6309
2.8	0.8408	0.5863
2.4	0.7832	0.5328
2.0	0.7008	0.4647
1.8	0.6476	0.4246
1.6	0.5844	0.3794
1.4	0.5108	0.3291
1.2	0.4276	0.2858
1.0	0.3360	0.2165
0.8	0.2410	0.1560
0.6	0.1494	0.0999
0.4	0.0716	0.0477
0.2	0.0188	0.0127
0	0.0000	0.0000

After Duncan and Buchignani (1976).



b/z	I_σ	
	Boussinesq	Westergaard
∞	1.000	1.000
100	1.000	0.990
10	0.997	0.910
9	0.996	0.901
8	0.994	0.888
7	0.991	0.874
6.5	0.989	0.864
6.0	0.986	0.853
5.5	0.983	0.835
5.0	0.977	0.824
4.5	0.970	0.807
4.0	0.960	0.784
3.5	0.943	0.756
3.0	0.920	0.719
2.5	0.889	0.672
2.0	0.817	0.608
1.5	0.716	0.519
1.2	0.624	0.448
1.0	0.550	0.392
0.8	0.462	0.328
0.5	0.306	0.216
0.2	0.127	0.089
0.1	0.064	0.045
0	0.000	0.000

After Duncan and Buchignani (1976).

TABLE 10.3 Influence Values for Vertical Stress Under Corner of a Uniformly Loaded Rectangular Area

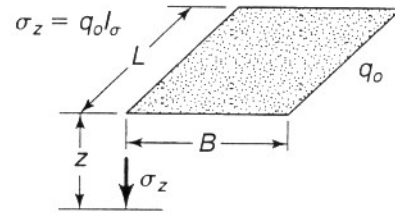

Boussinesq Case

B/z	L/z							
	0.1	0.2	0.4	0.6	0.8	1.0	2.0	∞
0.1	0.005	0.009	0.017	0.022	0.026	0.028	0.031	0.032
0.2	0.009	0.018	0.033	0.043	0.050	0.055	0.061	0.062
0.4	0.017	0.033	0.060	0.080	0.093	0.101	0.113	0.115
0.6	0.022	0.043	0.080	0.107	0.125	0.136	0.153	0.156
0.8	0.026	0.050	0.093	0.125	0.146	0.160	0.181	0.185
1.0	0.028	0.055	0.101	0.136	0.160	0.175	0.200	0.205
2.0	0.031	0.061	0.113	0.153	0.181	0.200	0.232	0.240
∞	0.032	0.062	0.115	0.156	0.185	0.205	0.240	0.250

Westergaard Case

B/z	L/z							
	0.1	0.2	0.4	0.6	0.8	1.0	2.0	∞
0.1	0.003	0.006	0.011	0.014	0.017	0.018	0.021	0.022
0.2	0.006	0.012	0.021	0.028	0.033	0.036	0.041	0.044
0.4	0.011	0.021	0.039	0.052	0.060	0.066	0.077	0.082
0.6	0.014	0.028	0.052	0.069	0.081	0.089	0.104	0.112
0.8	0.017	0.033	0.060	0.081	0.095	0.105	0.125	0.135
1.0	0.018	0.036	0.066	0.089	0.105	0.116	0.140	0.152
2.0	0.021	0.041	0.077	0.104	0.125	0.140	0.174	0.196
∞	0.022	0.044	0.082	0.112	0.135	0.152	0.196	0.250

After Duncan and Buchignani (1976).

Rigid Foundations

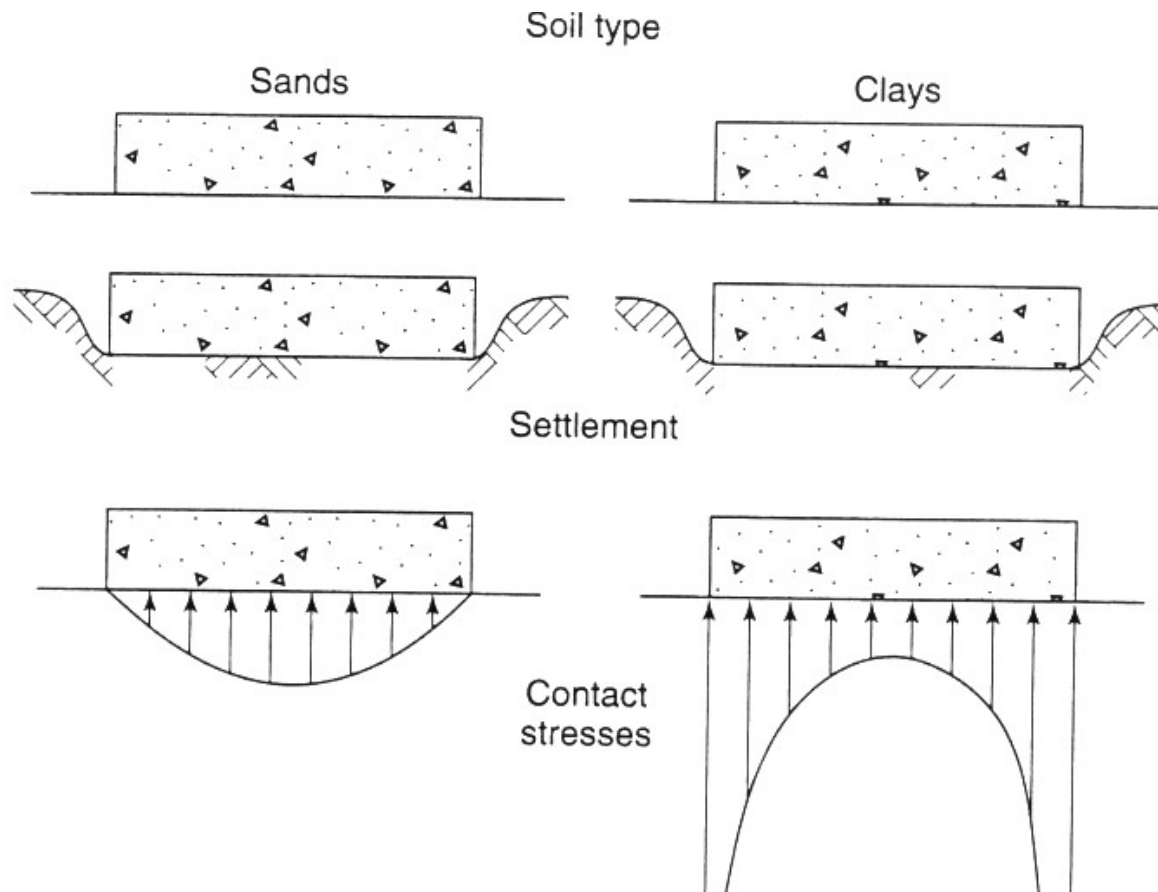

Flexible Foundations

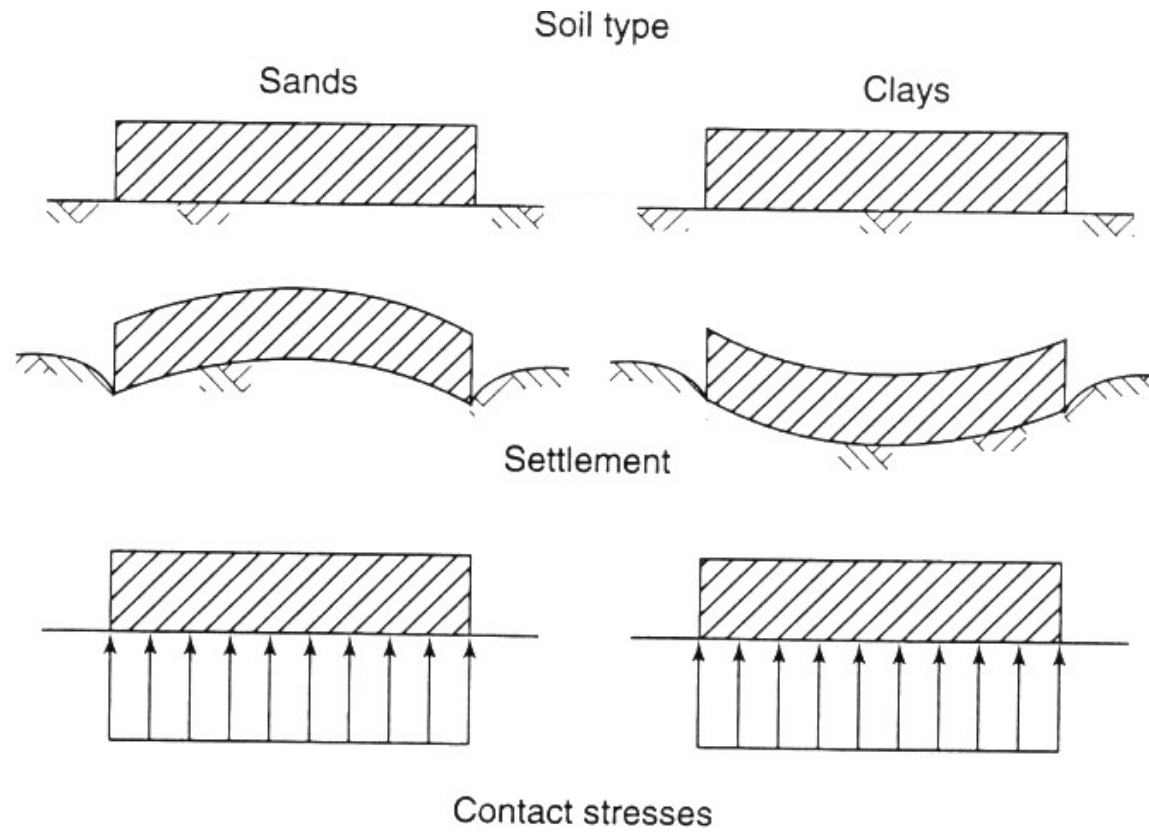
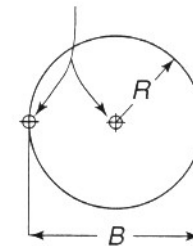
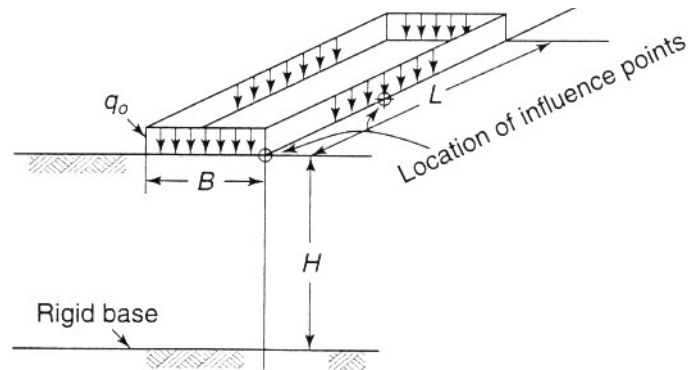

TABLE 10.4 Shape and Rigidity Factors, I_s , for Calculating Settlements of Points on Loaded Areas at the Surface of an Elastic Half-Space

a. Loaded Areas on Surface of Infinite Depth

Shape and Rigidity	Center	Corner	Edge/Middle of Long Side	Average
Circle (flexible)	1.0		0.64	0.85
Circle (rigid)	0.79		0.79	0.79
Square (flexible)	1.12	0.56	0.76	0.95
Square (rigid)	0.82	0.82	0.82	0.82
Rectangle (flexible)				
length/width				
2	1.53	0.76	1.12	1.30
5	2.10	1.05	1.68	1.82
10	2.56	1.28	2.10	2.24
Rectangle (rigid)				
length/width				
2	1.12	1.12	1.12	1.12
5	1.6	1.6	1.6	1.6
10	2.0	2.0	2.0	2.0



b. Loaded Areas on Surface over a Rigid Base (see figure below)

H/B	Center of Rigid Circular Area, Diameter = B	Corner of Flexible Rectangular Area				
		$L/B = 1$	$L/B = 2$	$L/B = 5$	$L/B = 10$	$L/B = \infty$
For Poisson's ratio $\nu = 0.5$						
0	0.00	0.00	0.00	0.00	0.00	0.00
0.5	0.14	0.05	0.04	0.04	0.04	0.04
1	0.35	0.15	0.12	0.10	0.10	0.10
1.5	0.48	0.23	0.22	0.18	0.18	0.18
2.0	0.54	0.29	0.29	0.27	0.26	0.26
3.0	0.62	0.36	0.40	0.39	0.38	0.37
5.0	0.69	0.44	0.52	0.55	0.54	0.52
10	0.74	0.48	0.64	0.76	0.77	0.73
For Poisson's ratio $\nu = 0.33$						
0	0.00	0.00	0.00	0.00	0.00	0.00
0.5	0.20	0.09	0.08	0.08	0.08	0.08
1.0	0.40	0.19	0.18	0.16	0.18	0.16
1.5	0.51	0.27	0.28	0.25	0.25	0.25
2.0	0.57	0.32	0.34	0.34	0.34	0.34
3.0	0.64	0.38	0.44	0.46	0.45	0.45
5.0	0.70	0.48	0.56	0.60	0.61	0.61
10	0.74	0.49	0.66	0.80	0.82	0.81

After U.S. Navy (1986).

