

Development Length

**A.** An 18-ft normal-weight concrete cantilever beam is subjected to a factored  $M_u = 3,500$  in-kips and a factored shear  $V_u = 32.0$  kips at the face of the support. Design the top reinforcement and the appropriate embedment of 90° hook into the concrete wall to sustain the external shear and moment given:

$$f_y = 60 \text{ ksi};$$
$$f'_c = 4,500 \text{ psi}$$

**B.** Design the beam reinforcement in problem A above if it was simply supported having a span  $l_n = 36$  ft and subject to the same factored  $M_u$  value at midspan and the shear  $V_u$  at the fact of the support. Evaluate the required embedment length at the support to ensure that no bond failure due to slippage can develop. Assume (a) confining beam reaction and (b) beam not monolithic with its support.

Bar Cutoff Problems

C. A floor system consists of single span T-beams 8 ft on centers, supported by 12 in masonry walls spaced at 25 ft between inside faces. The general arrangement is shown in below. A 5 inch monolithic slab to be used in heavy storage warehouse. Determine the reinforcement configuration and the cutoff points. Check the provisions of ACI 318 for bar cutoff.

$f'_c = 4,000$  psi (normal weight)

$f_y = 60,000$  psi

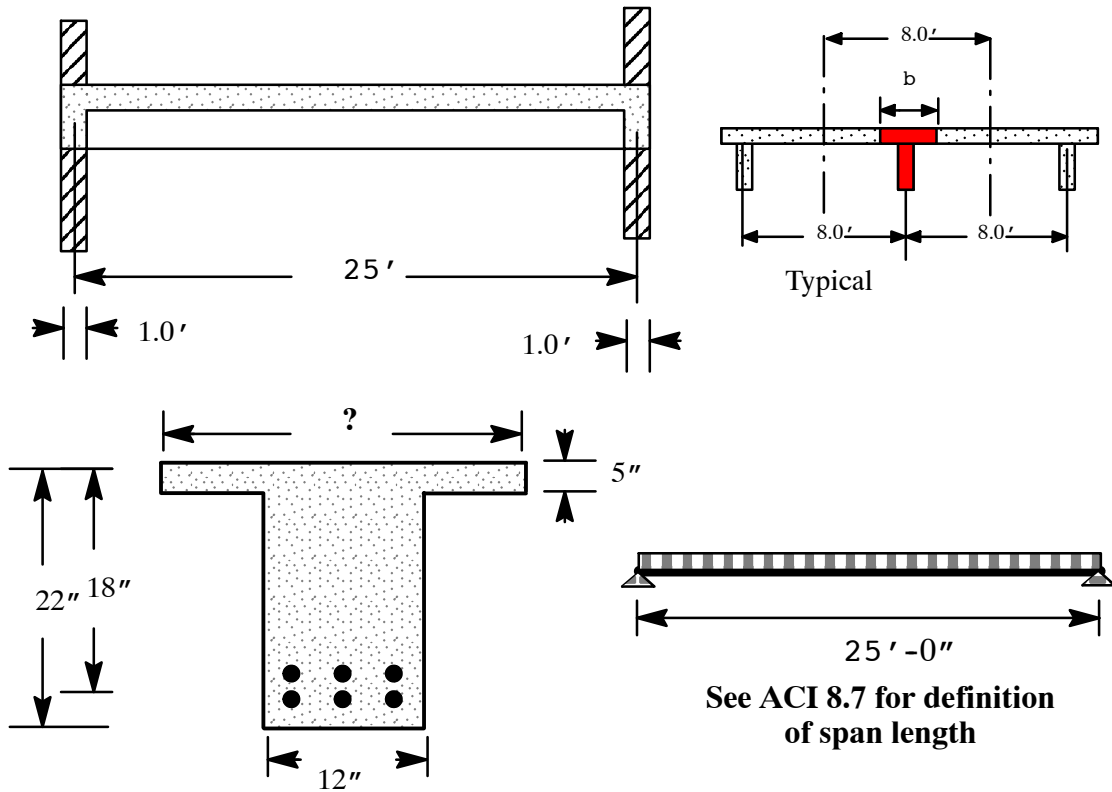

D.