

# Marshall Mix Design

# Asphalt Concrete Properties



# Stability

The ability to withstand traffic loads without distortion or deflection, especially at higher temperatures.

To get good stability, use strong, rough, dense-graded, cubical aggregate with just enough binder to coat the aggregate particles. Excess asphalt cement lubricates the aggregate particles and lets them slide past each other more easily (which reduces stability). But a thick asphalt coating provides good flexibility to resist cracking, which is desirable. Hmmm...

# Workability

The ability to be placed and compacted with reasonable effort and without segregation of the coarse aggregate.

Too much asphalt cement makes the mix tender. Too little asphalt cement makes it hard to compact. Too much natural sand can also make the mix tender because natural sand has smooth, round grains. Hmmm...

# Skid Resistance

Proper traction in wet and dry conditions.

To get good skid resistance, use smaller aggregate so there are lots of contact points, use hard aggregate that doesn't polish and make sure you have enough air voids to prevent bleeding.

Some states now use an open-graded friction course (OGFC) that allows water to drain to the sides of the pavement, eliminating hydroplaning. But OGFC is not very durable because of the open pores. Hmmm...

# Durability

The ability to resist aggregate breakdown due to wetting and drying, freezing and thawing, or excessive inter-particle forces.

To get good durability, use strong, tough, nonporous aggregate and enough asphalt cement to completely coat all of the aggregate particles (to keep them dry) and fill all of the voids between particles (to slow the oxidation of the asphalt cement). But this reduces stability. Hmmm...

# Stripping

Separation of the asphalt cement coating from the aggregate due to water getting between the asphalt and the aggregate.

To reduce stripping, use clean, rough, hydrophobic aggregate and add enough asphalt cement to provide a thick coating of asphalt on every aggregate particle. This improves durability but decreases stability.

# Bleeding

The migration of asphalt cement to the surface of the pavement under wheel loads, especially at higher temperatures.

To prevent bleeding, incorporate enough air voids so the asphalt can compress by closing air voids rather than by squeezing asphalt cement out from between the aggregate particles.

# Fatigue Cracking

Cracking resulting from repeated flexure of the asphalt concrete due to traffic loads.

To minimize fatigue cracking, use the proper asphalt cement grade and have a thick asphalt cement coating to make the concrete flexible. This improves durability but decreases stability.

# Thermal Cracking

Cracking that results from an inability to acclimate to a sudden drop in temperature.

To minimize thermal cracking, use the proper asphalt cement grade.

# Mix Design Basics

- ⊕ **The right grade of asphalt cement**

Relates to fatigue cracking, thermal cracking, stability

- ⊕ **The right type of aggregate**

Relates to stability, durability, stripping, skid resistance

- ⊕ **The right mix volumetrics**

Relates to stability, durability, stripping, bleeding, skid resistance

# Marshall Mix Design

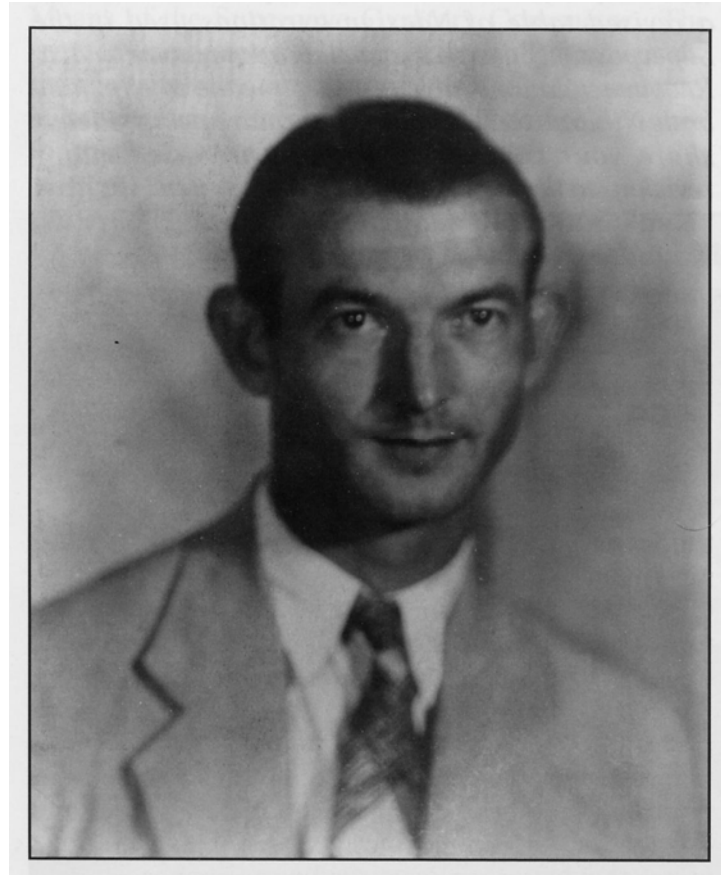

Bruce Marshall, Mississippi Highway Department

# Marshall Mix Design Steps

1. Create aggregate blend to meet gradation specifications.
2. Establish mixing and compaction temperatures from the viscosity-temperature chart.
3. Compact three specimens at each of five asphalt contents spanning the expected optimum asphalt content.
4. Determine the relative density of each specimen and the mix volumetrics ( $\rho_{mb}$ , AV, VMA, VFA).
5. Measure the performance properties of the each specimen at 60°C (140°F).

# Marshall Specimens

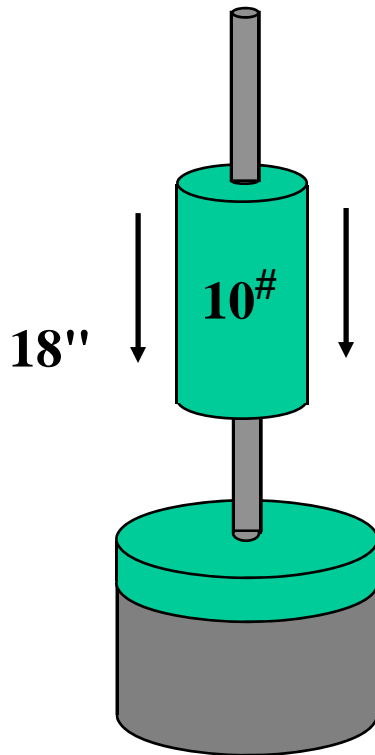

*Make 3 specimens at each of  
5 different asphalt contents*

<b>Traffic</b>	<b>Blows / Side</b>
<b>Light</b>	<b>35</b>
<b>Medium</b>	<b>50</b>
<b>Heavy</b>	<b>75</b>

# Marshall Hammer

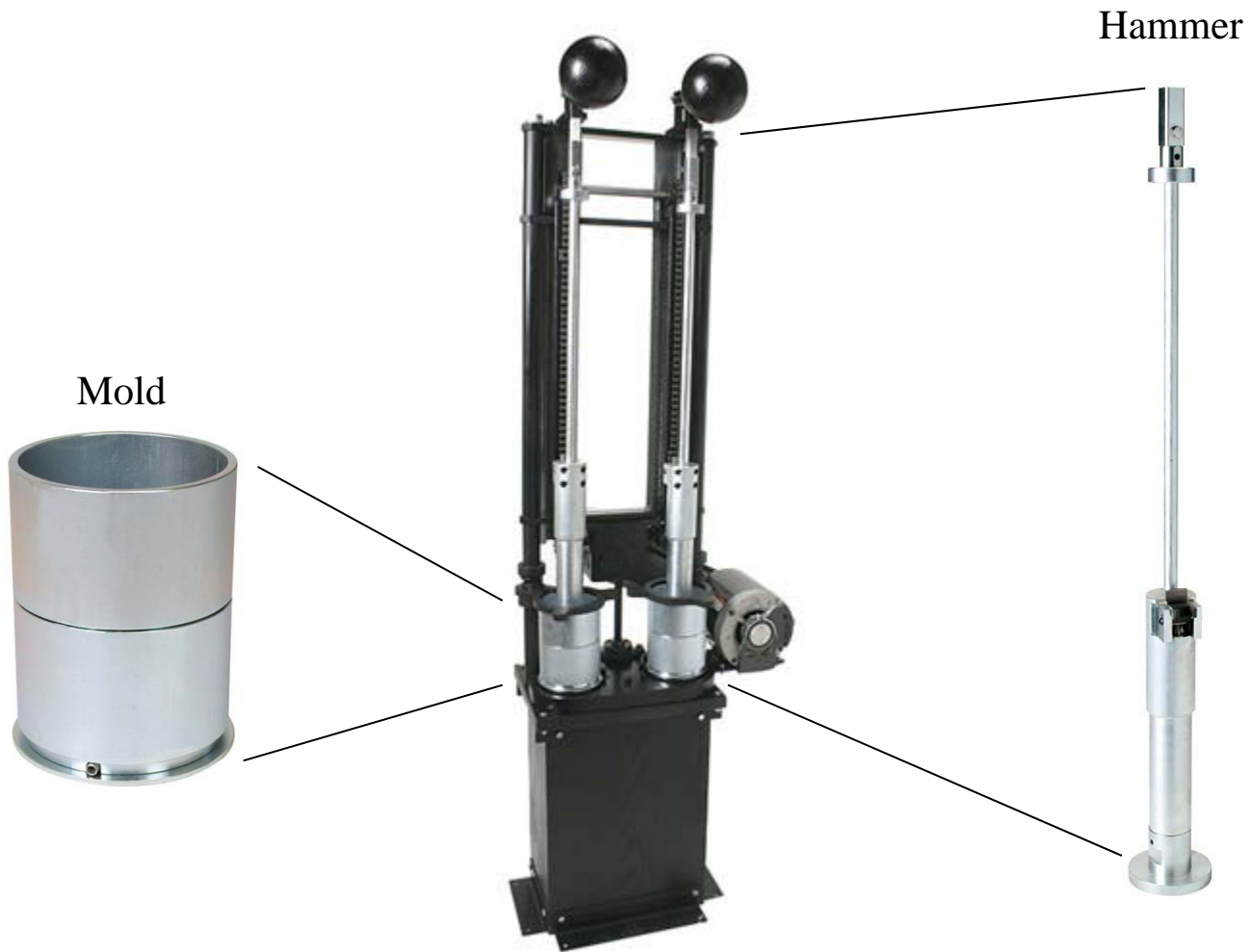

# Stability and Flow Test

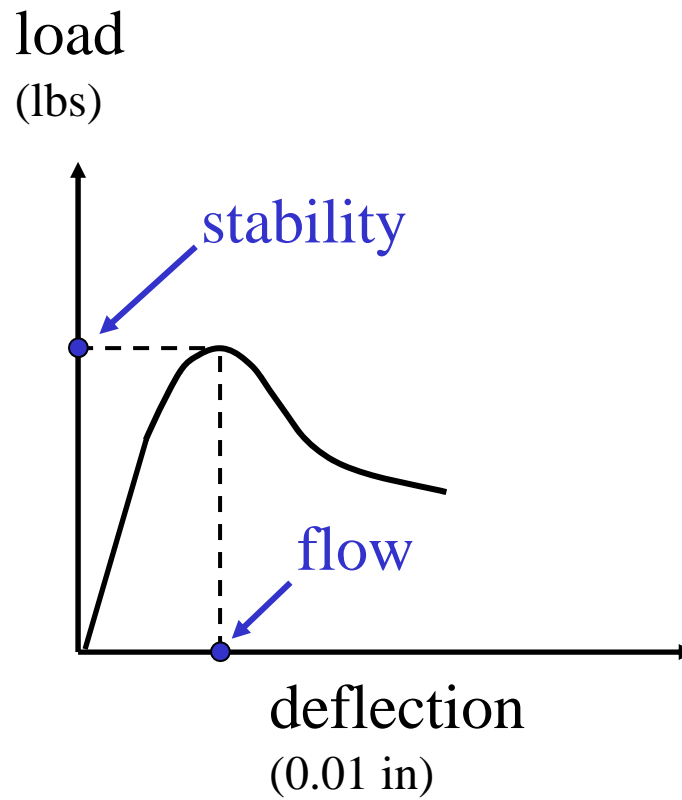
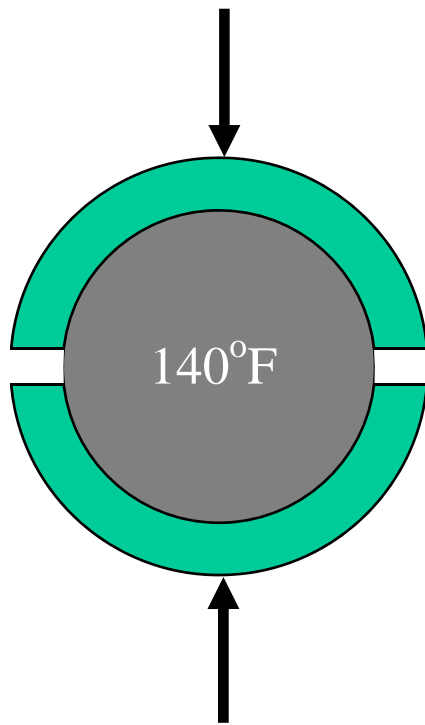

# Stability and Flow Test



# Marshall Mix Design

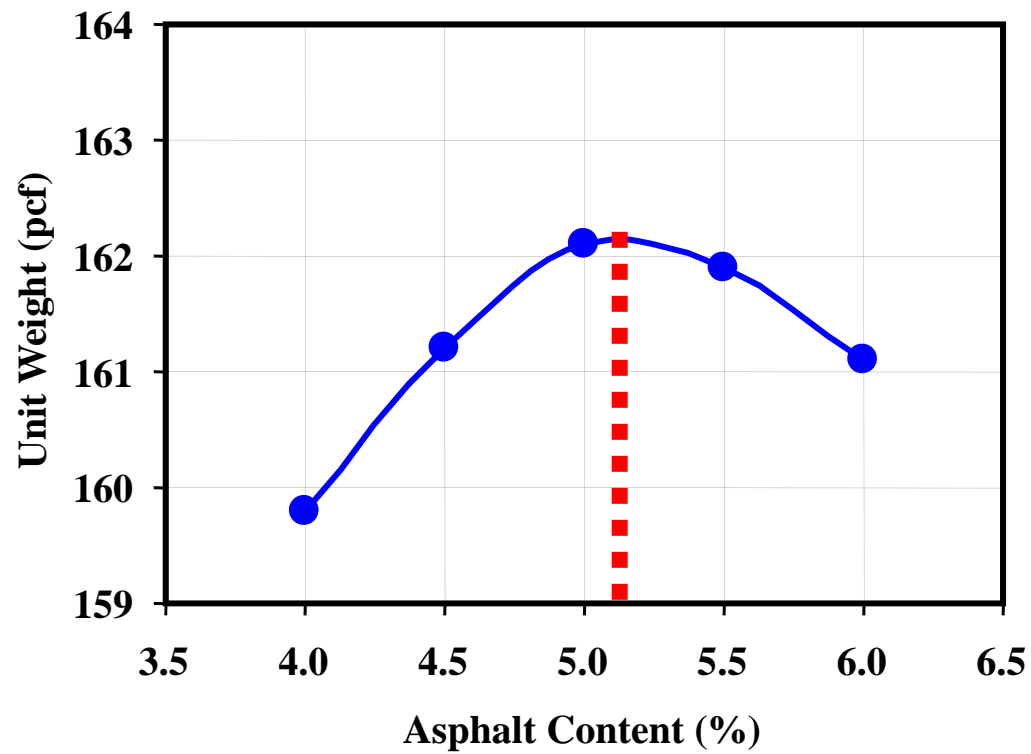

# Marshall Mix Design

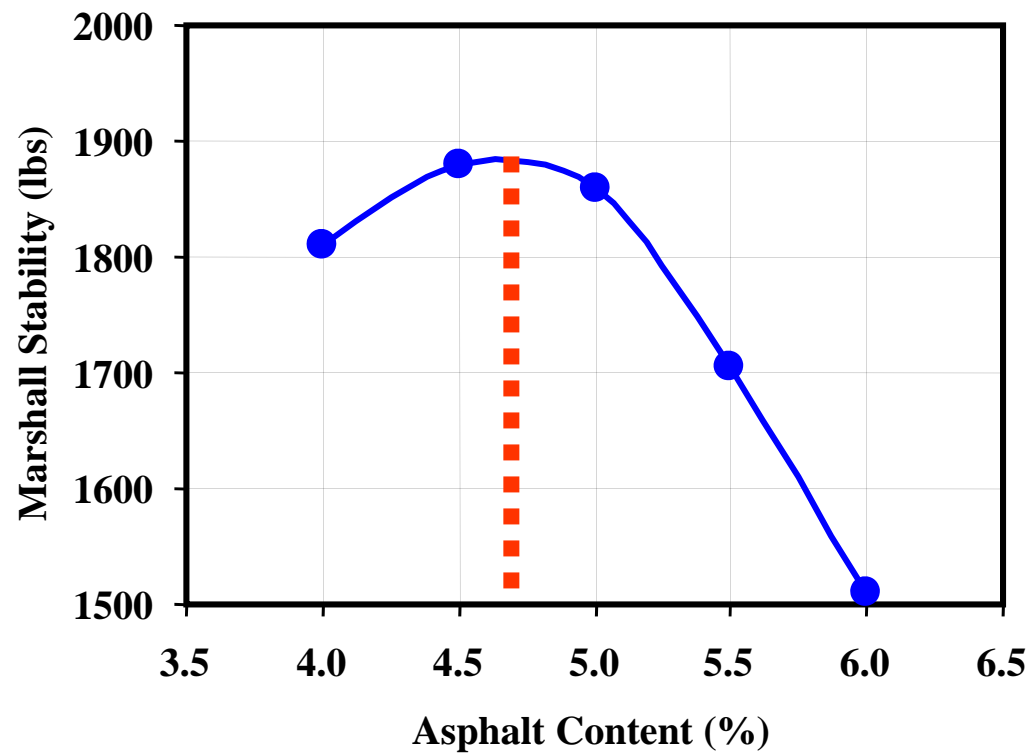

# Marshall Mix Design

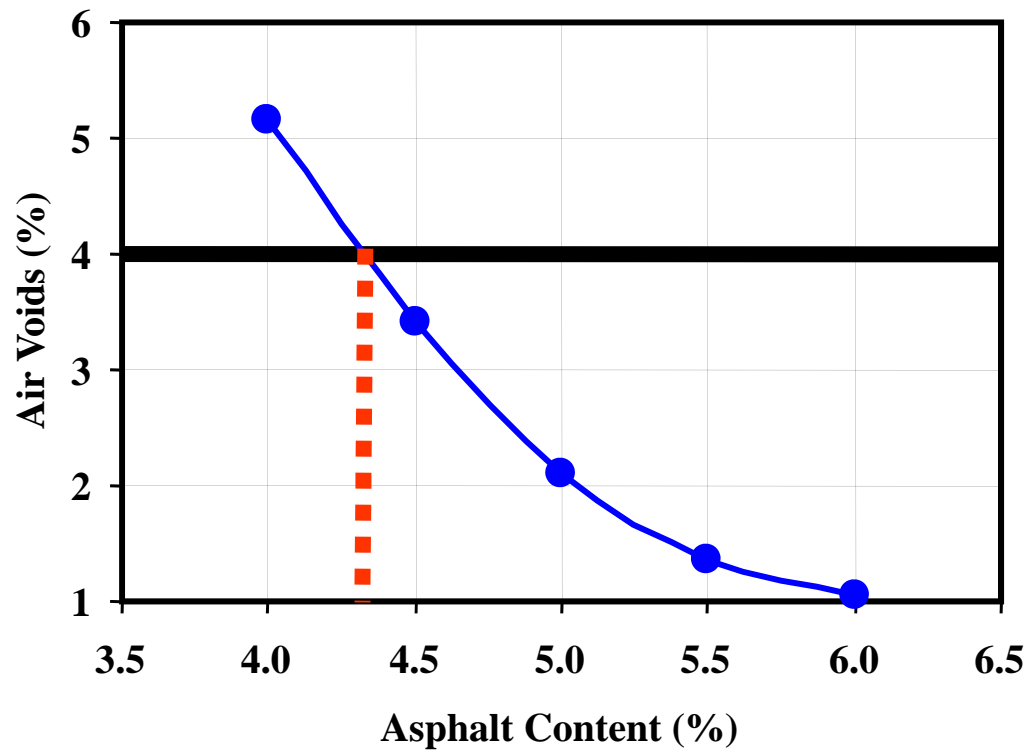

# Marshall Mix Design

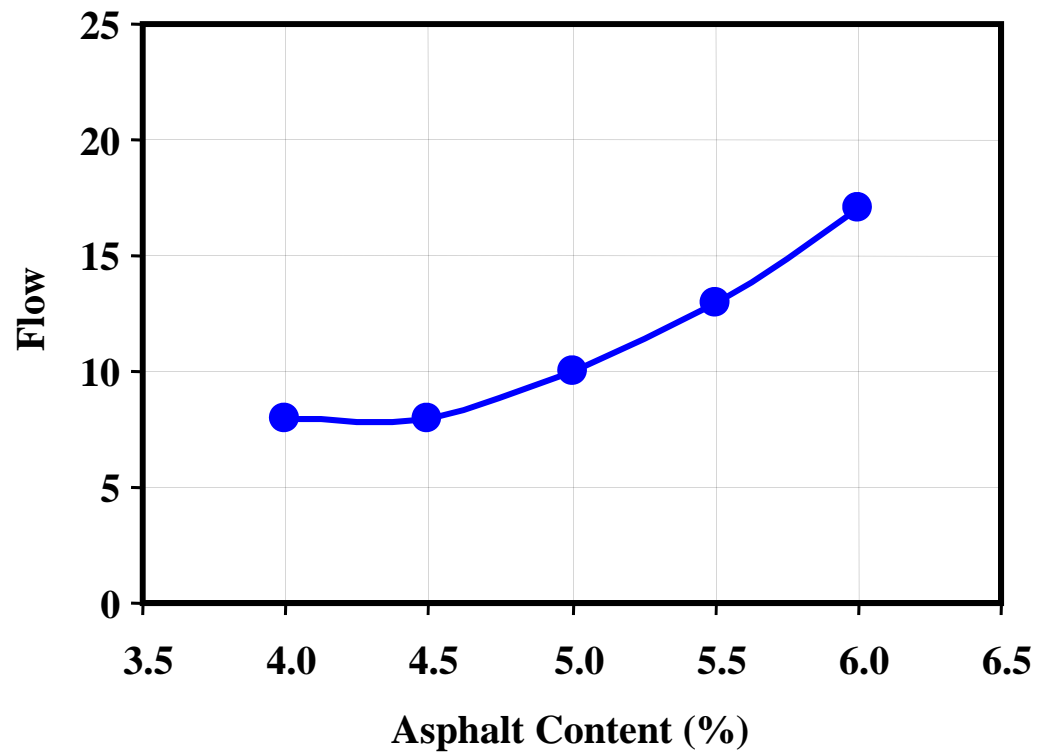

# Marshall Mix Design

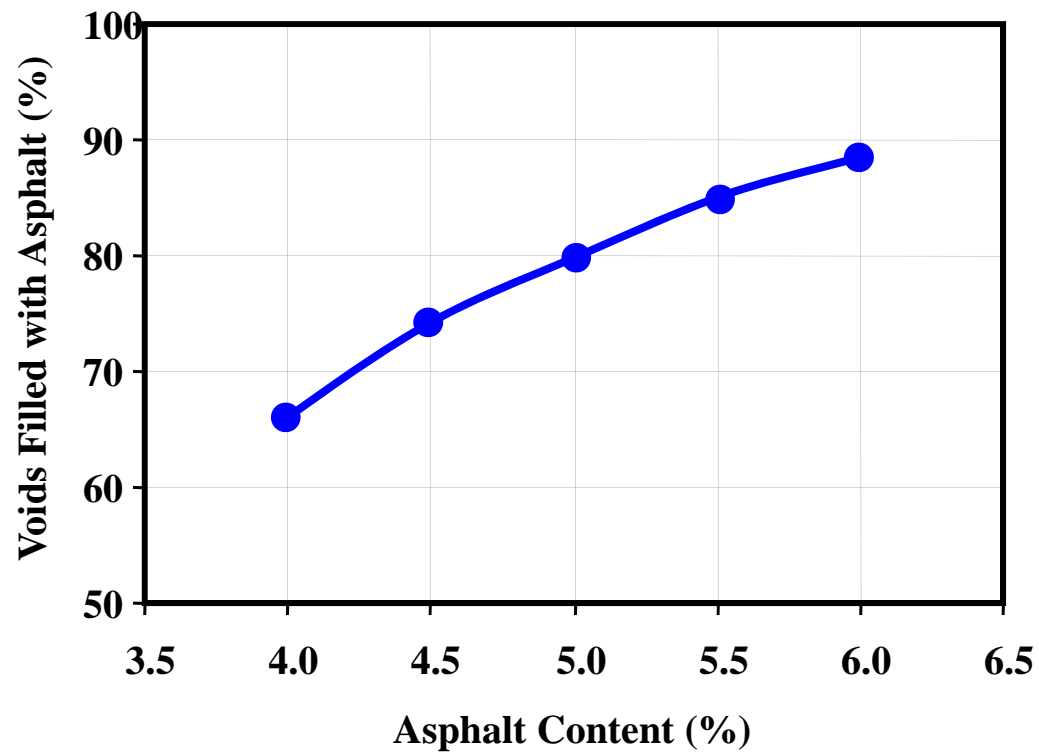

# Marshall Mix Design

(The Asphalt Institute Procedure)

$$AC = \frac{\begin{array}{c} \text{Maximum} \\ \text{Density} \end{array} 5.1 + \begin{array}{c} \text{Maximum} \\ \text{Stability} \end{array} 4.7 + \begin{array}{c} 4\% \text{ Air} \\ \text{Voids} \end{array} 4.3}{3} = 4.7\%$$

# Marshall Mix Design

(The NAPA Procedure)

$$\text{AC} = \frac{\begin{array}{ccc} \text{Maximum} & \text{Maximum} & \text{4\% Air} \\ \text{Density} & \text{Stability} & \text{Voids} \\ \hline \cancel{5.1} & + \cancel{4.7} & + 4.3 \end{array}}{1} = 4.3\%$$

**This is what TDOT uses**

**Table 6-10 Suggested Criteria for Asphalt Concrete Design by the Marshall Method \***

<i>Marshall Method Mix Criteria<sup>1</sup></i>	<i>Light Traffic Surface &amp; Base</i>		<i>Medium Traffic Surface &amp; Base</i>		<i>Heavy Traffic Surface &amp; Base</i>	
	<i>Min</i>	<i>Max</i>	<i>Min</i>	<i>Max</i>	<i>Min</i>	<i>Max</i>
Compaction, number of blows each end of specimen	35		50		75	
Stability, N	3336	—	5338	—	8006	—
(lb)	(750)	—	(1200)	—	(1800)	—
Flow, 0.25 mm (0.01 in.)	8	18	8	16	8	14
Percent Air Voids	3	5	3	5	3	5
Percent Voids Filled With Asphalt (VFA)	70	80	65	78	65	75
<i>Minimum VMA (%) (varies with air voids and aggregate size)</i>						
<i>Nominal Maximum Particle Size<sup>1, 2</sup></i>		<i>Design Air Voids, Percent<sup>3</sup></i>				
<i>mm</i>	<i>in.</i>	<i>3.0</i>	<i>4.0</i>	<i>5.0</i>	<i>6.0</i>	<i>7.0</i>
1.18	No. 16	21.5	22.5	23.5	24.5	25.5
2.36	No. 8	19.0	20.0	21.0	22.0	23.0
4.75	No. 4	16.0	17.0	18.0	19.0	20.0
9.5	3/8	14.0	15.0	16.0	17.0	18.0
12.5	1/2	13.0	14.0	15.0	16.0	17.0
19.0	3/4	12.0	13.0	14.0	15.0	16.0
25.0	1.0	11.0	12.0	13.0	14.0	15.0
37.5	1.5	10.0	11.0	12.0	13.0	14.0
50	2.0	9.5	10.5	11.5	12.5	13.5
63	2.5	9.0	10.0	11.0	12.0	13.0

# VMA Criteria

(Assuming 4% Design Air Voids)

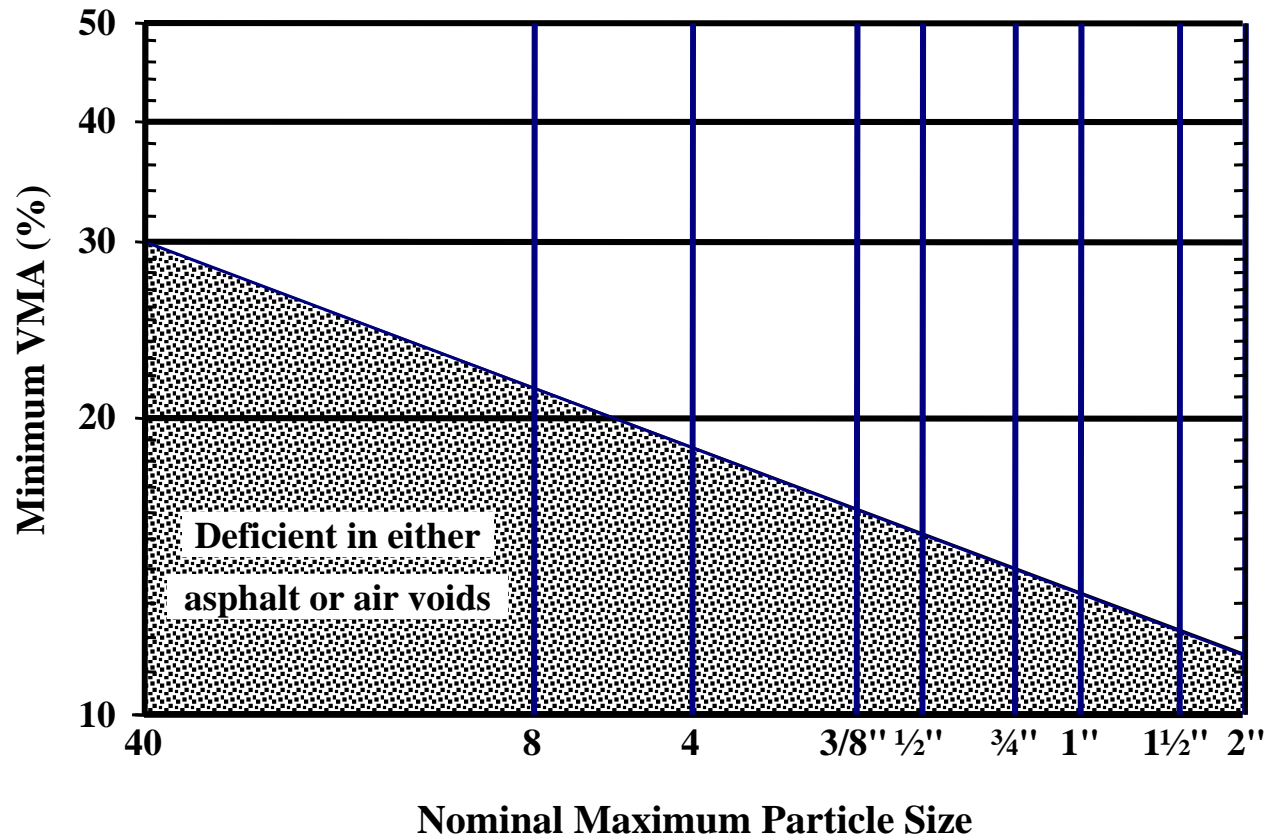

# VMA Criteria

(Assuming **5%** Design Air Voids)

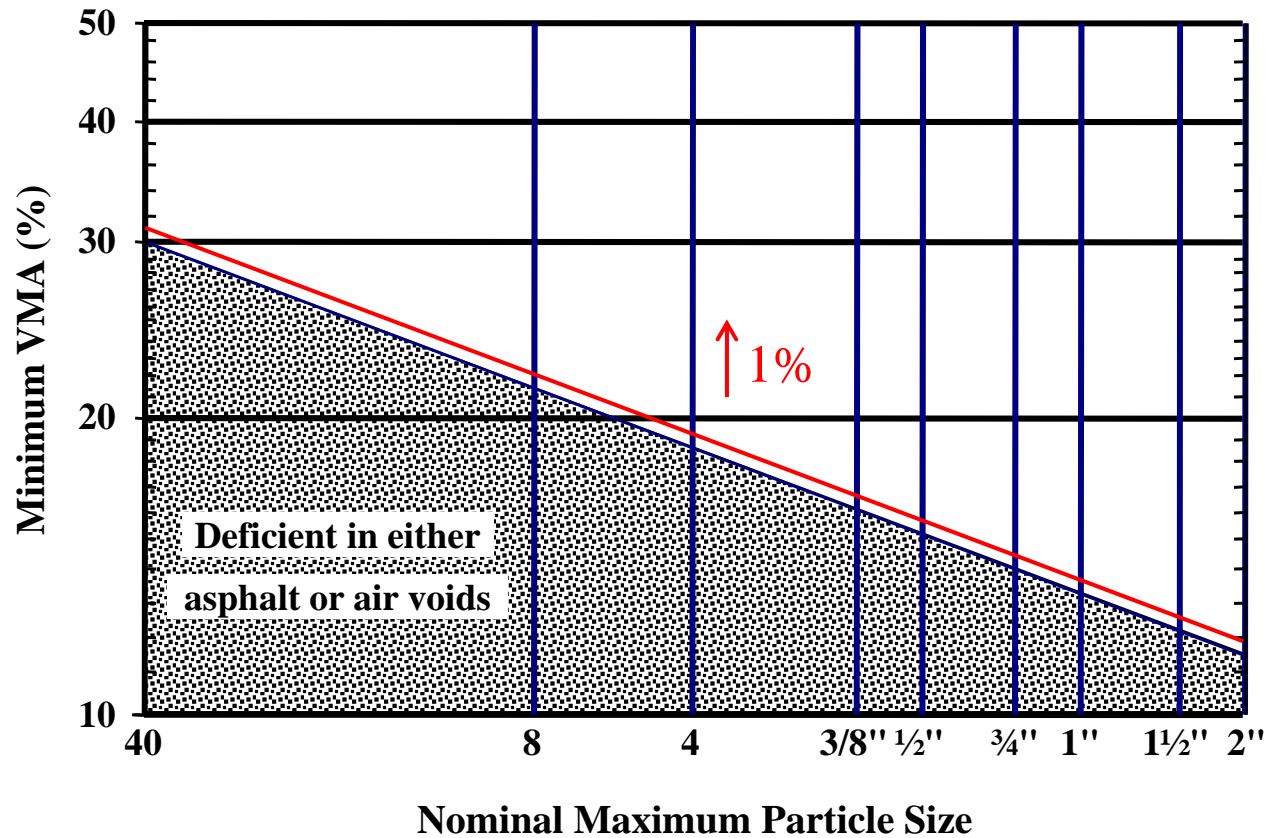

# VMA Criteria

(Assuming **3%** Design Air Voids)

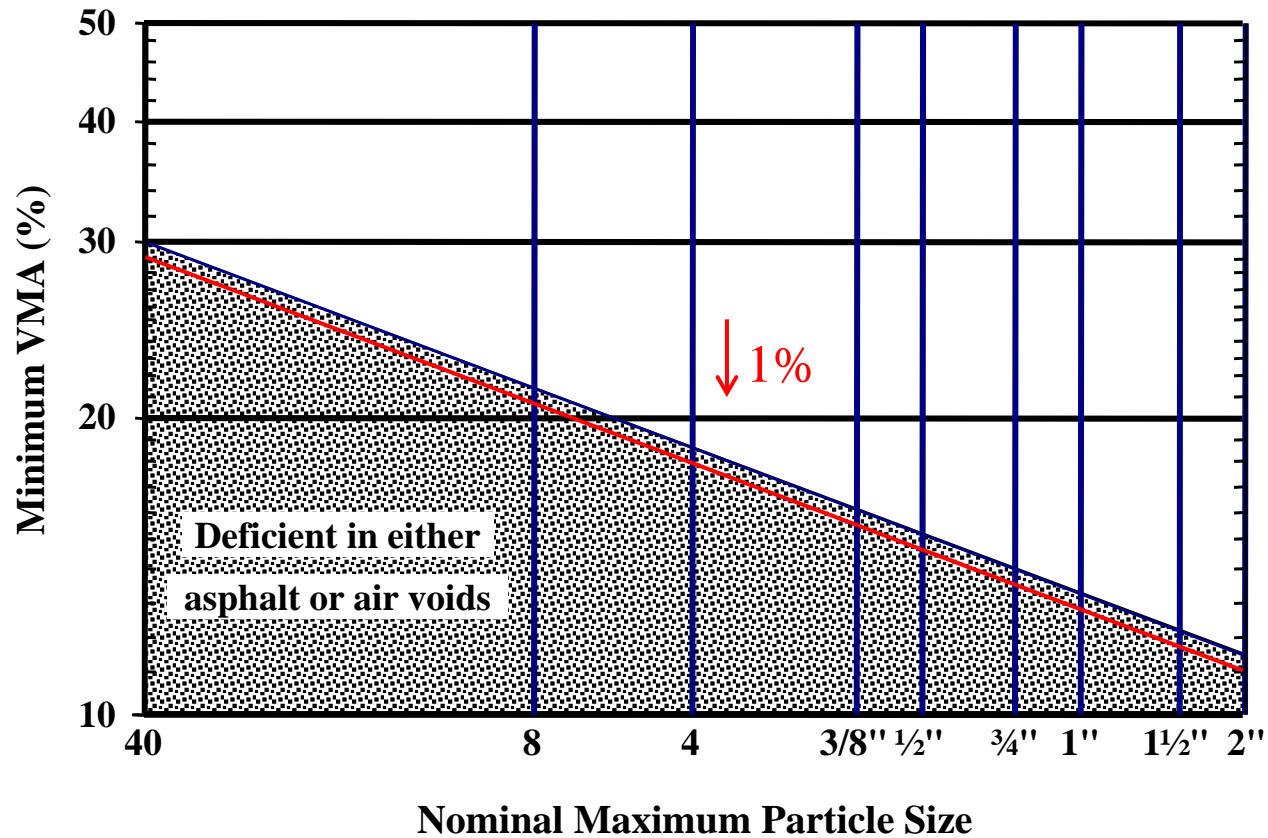

# Marshall Mix Design

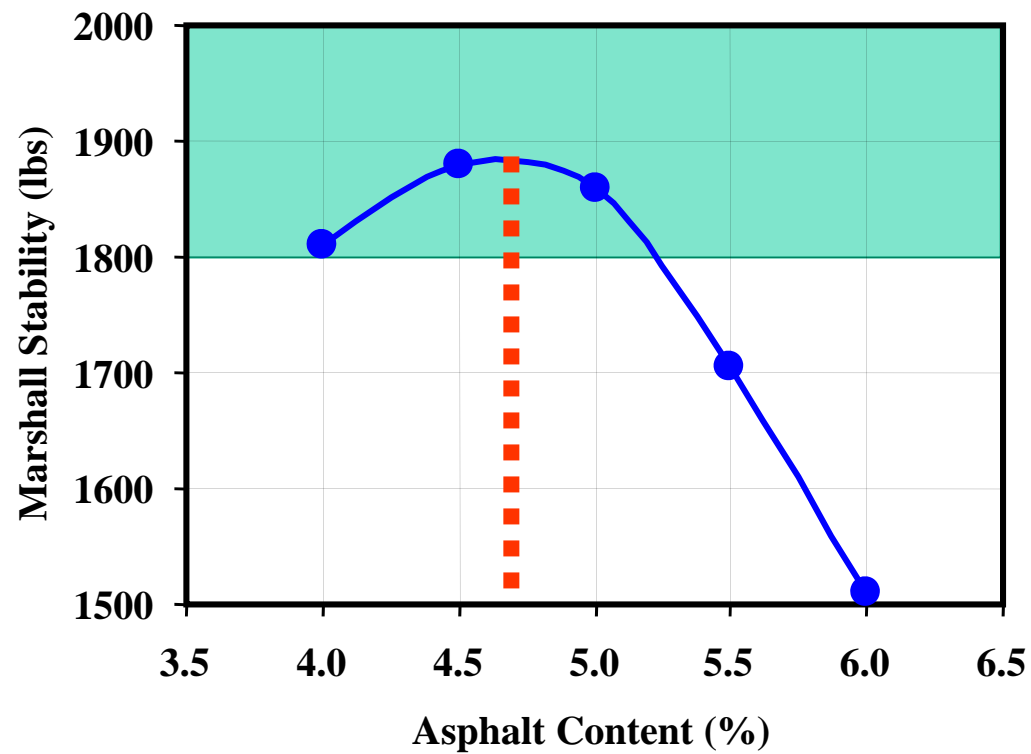

# Marshall Mix Design

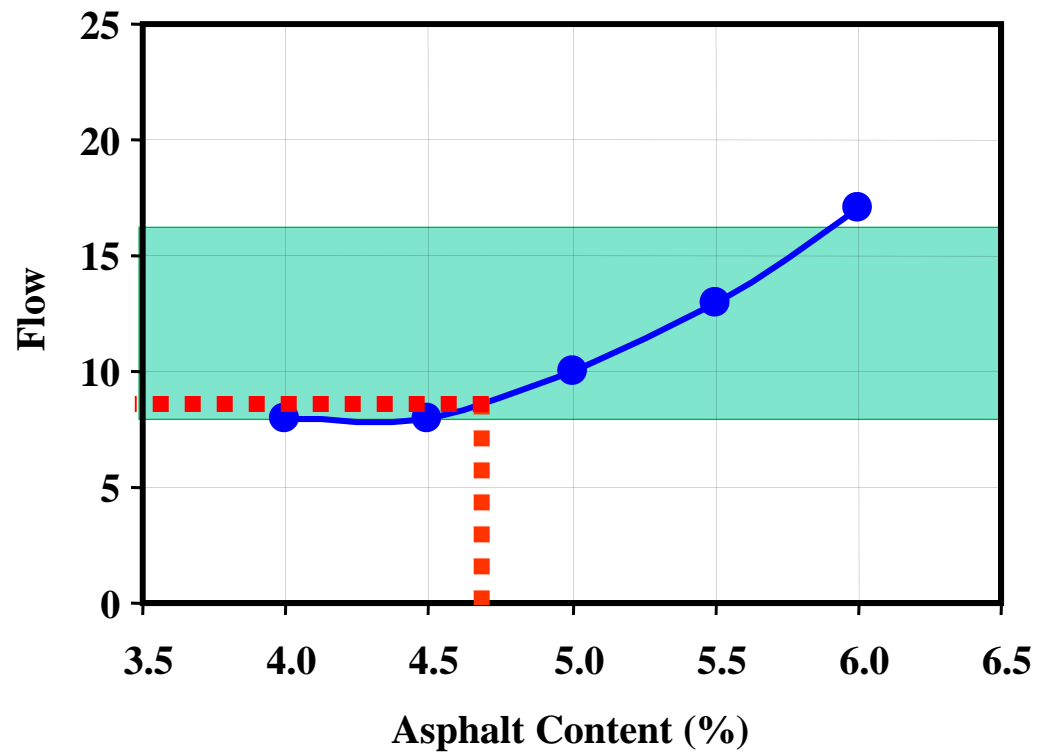

# Marshall Mix Design

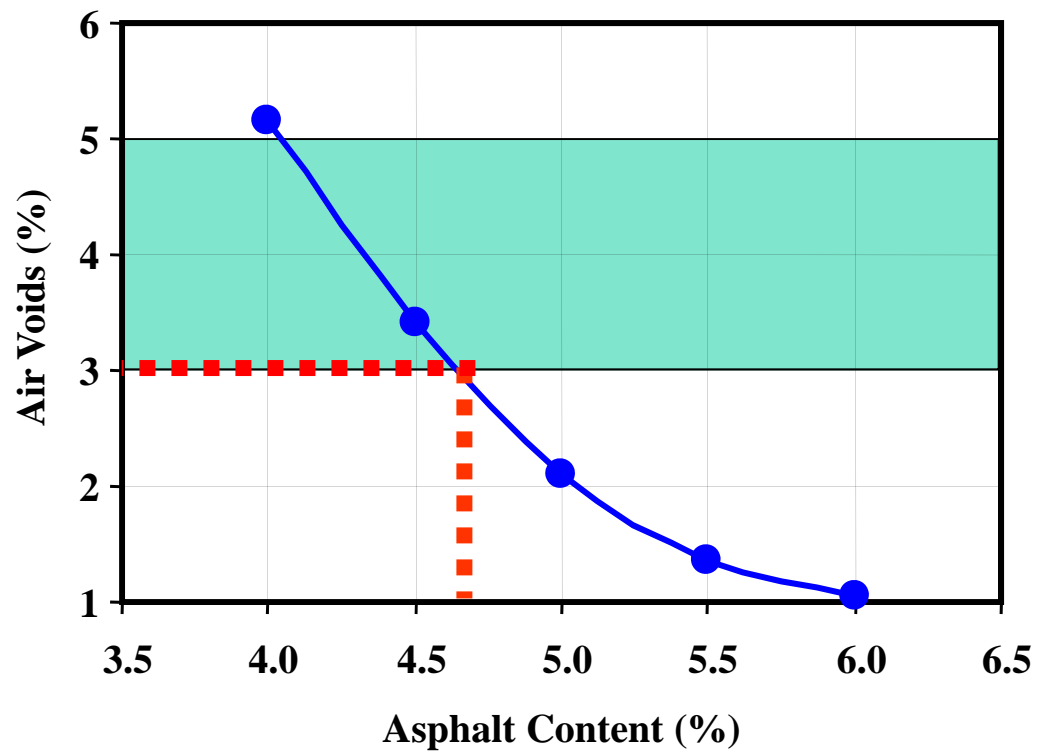

# Marshall Mix Design

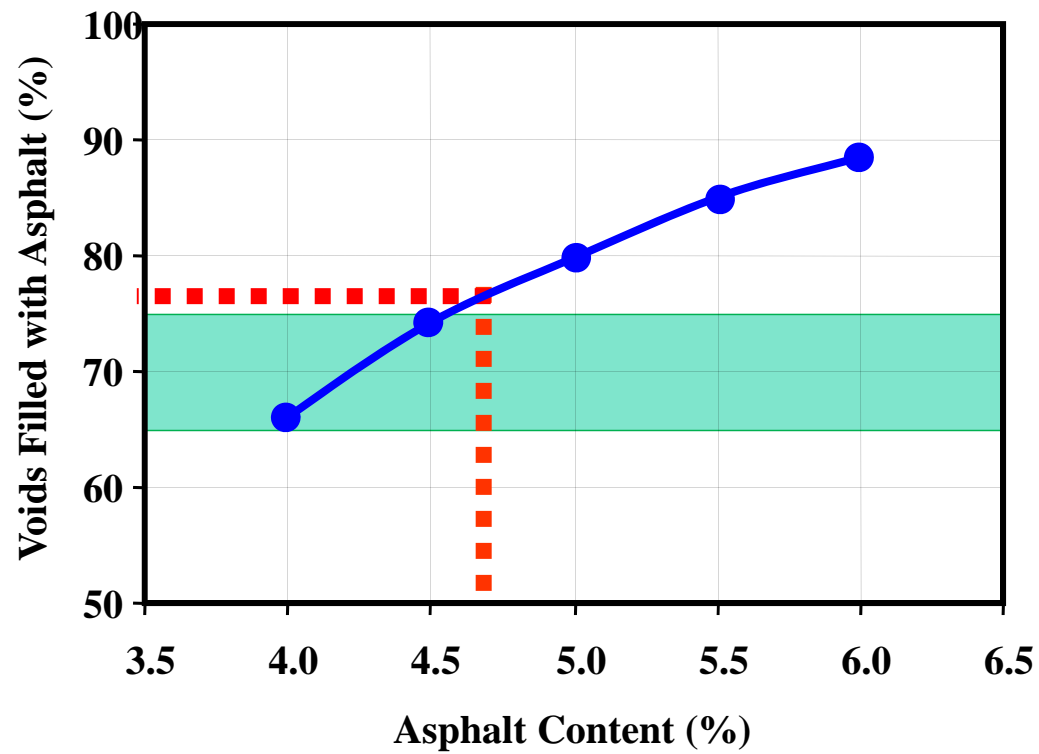

# VMA Criteria

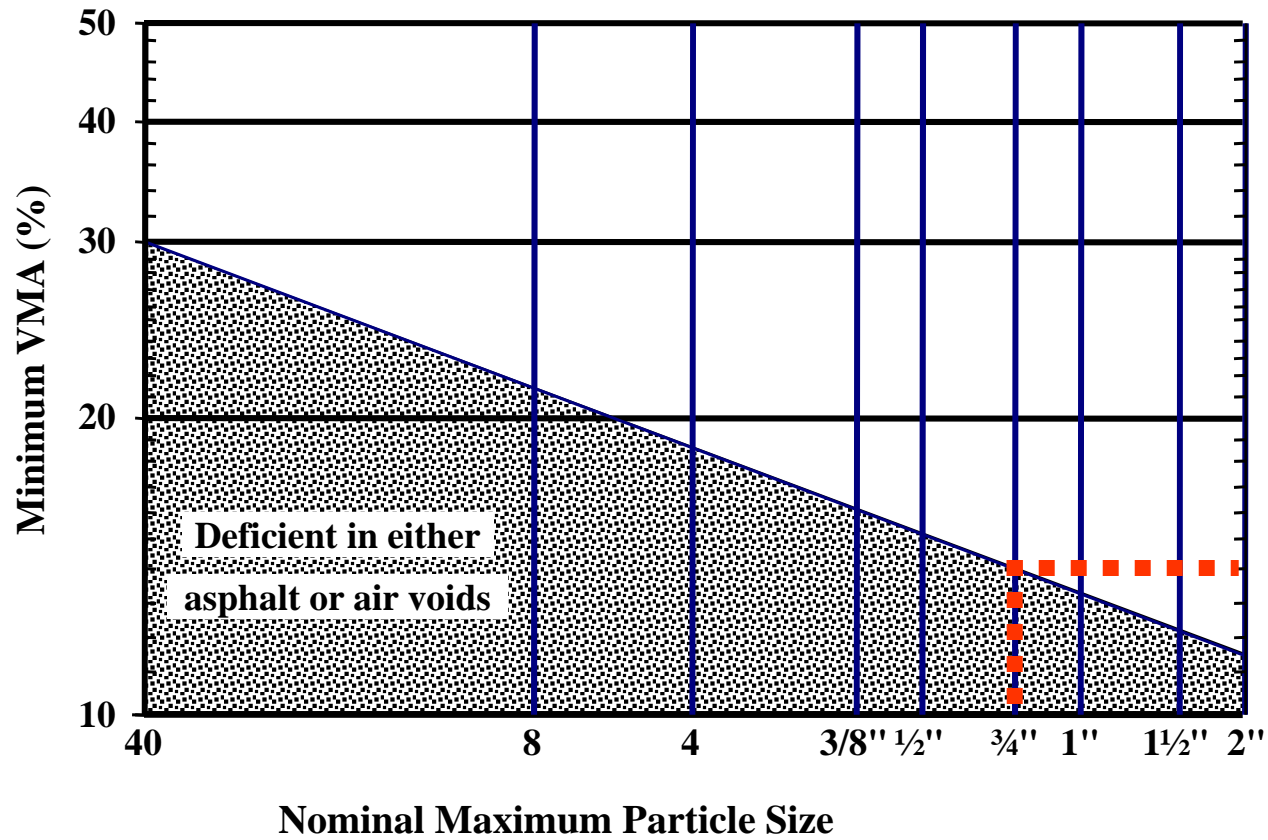

# Marshall Mix Design

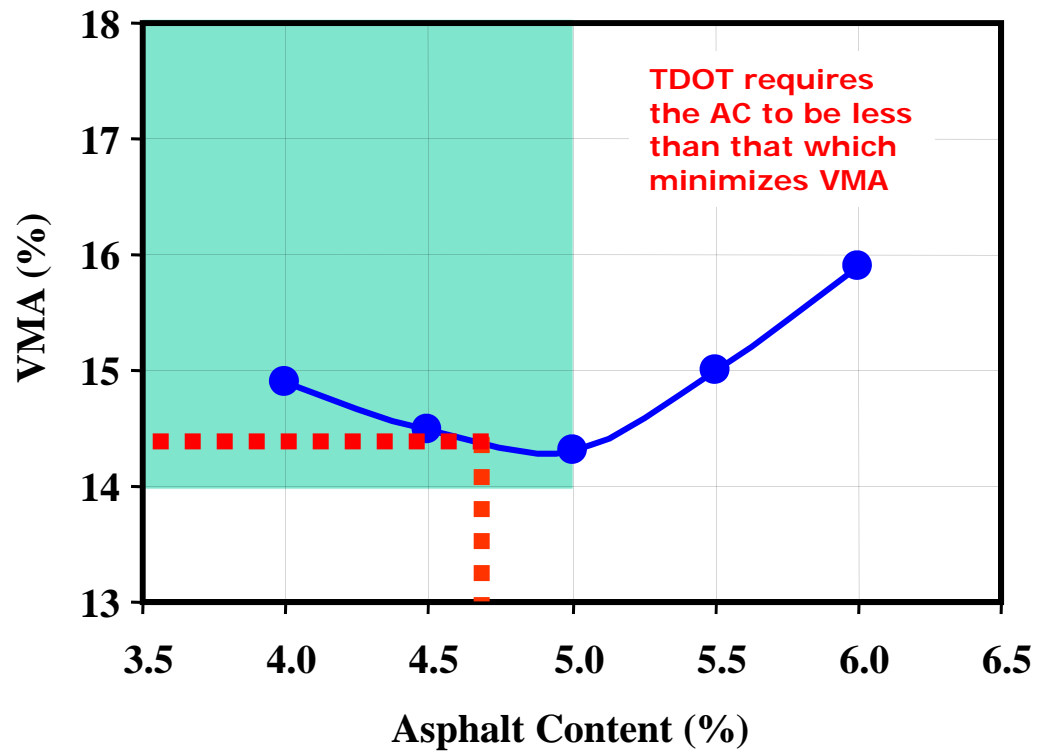

# Ways to Increase VMA

1. Reduce the dust content
2. Open the aggregate gradation
3. Gap-grade the aggregate blend
4. Increase manufactured sand
5. Reduce flat-and-elongated particles

