

5.2-2 An unsymmetrical flexural member consists of a $\frac{1}{2} \times 12$ (12.7 × 250 mm) top flange, a $\frac{1}{2} \times 7$ (12.7 × 180 mm) bottom flange, and a $\frac{3}{8} \times 16$ (9.5 × 400 mm) web.

- a. Determine the distance \bar{y} from the top of the shape to the horizontal plastic neutral axis.
- b. If A572 Grade 50 steel ($F_y = 50$ ksi (345 MPa)) is used, what is the plastic moment M_p for the horizontal plastic neutral axis?
- c. Compute the plastic section modulus Z with respect to the minor principal axis.

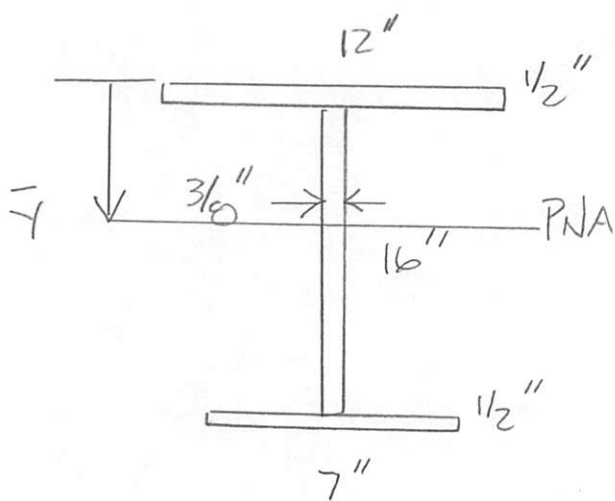

$$A_{\text{ABOVE PNA}} = A_{\text{BELOW PNA}}$$

$$12''(\frac{1}{2}) + (\bar{y} - \frac{1}{2}'')(\frac{3}{8}'') = \frac{3}{8}\bar{y} + 5.8125$$

$$= 7''(\frac{1}{2}) + (16 - \bar{y} + \frac{1}{2}) (\frac{3}{8}) = -\frac{3}{8}\bar{y} + 9.6875$$

$$\frac{3}{8}\bar{y} + 5.8125 = -\frac{3}{8}\bar{y} + 9.6875$$

$$\frac{3}{4}\bar{y} = 3.875 \quad \underline{\underline{\bar{y} = 5.1667 \text{ in}}}$$

$$b) M_p = F_y Z = F_y a \left(\frac{A}{Z} \right)$$

COMPONENT	A (IN ²)	y (IN)	Ay (IN ³)
TOP FLANGE	6	$\bar{y} - \frac{1}{4}'' = 4.9167$	29.500
TOP WEB	1.75	$\frac{\bar{y} - 1/2}{2} = 2.3333$	4.0834
	$(\bar{y} - 1/2)(\frac{3}{8})$		<hr/>
	7.75		33.500

5.2-2 | $\bar{y}_T = \frac{\sum Ay}{\sum A} = \frac{33.50 \text{ in}^3}{7.75 \text{ in}^2} = \underline{4.323 \text{ in}}$

COMPONENT	A (in ²)	y (in)	Ay (in ³)
BOTTOM FLANGE	7"(1/2") = 3.5	(16" + 1/2" - 7) + 1/4)	40.5416
BOTTOM WEB	(16" + 1/2" - 7)(3/16) = 4.25	11.5833 (16" + 1/2" - 7)/2 5.6667	24.0833
	7.75		64.6248

$\bar{y}_B = \frac{64.6248 \text{ in}^3}{7.75 \text{ in}^2} = \underline{8.3387 \text{ in}}$

$a = \bar{y}_T + \bar{y}_B = 12.6617 \text{ in}$

$M_p = F_y (12.6617 \text{ in}) (7.75 \text{ in}^2) = 4,906.41 \text{ k}\cdot\text{in} \approx 13 \text{ k}\cdot\text{m}$
 $= \underline{\underline{408.87 \text{ k}\cdot\text{ft}}}$

c) COMPUTE Z WITH TO MINOR AXIS (SYMMETRIC)

$\bar{x}_1 = \bar{x}_2$

COMPONENT	A (in ²)	x (in)	Ax (in ³)
BOTTOM FLANGE	(3.5")(1/2") = 1.75	1/2(3.5") = 1.75	3.0625
TOP FLANGE	(6")(1/2") = 3	1/2(6") = 3	9.0
WEB	(16")(3/16) = 3	1/2(3/16) = 0.0938	0.2813
	7.75		12.3438

$$\frac{5.2-2}{\bar{x}} = \frac{\sum A_x}{\sum A} = \frac{12.3438 \text{ in}^3}{7.75 \text{ in}^2} = \underline{1.5927 \text{ in}}$$

3/3

$$\bar{z} = \bar{x} \left(\frac{A}{Z} \right) = 2(1.5927 \text{ in})(7.75 \text{ in}^2) = \underline{\underline{24.6875 \text{ in}^3}}$$