

Example 4b-1 - Determine the internal shear and bending moment as a function of x .

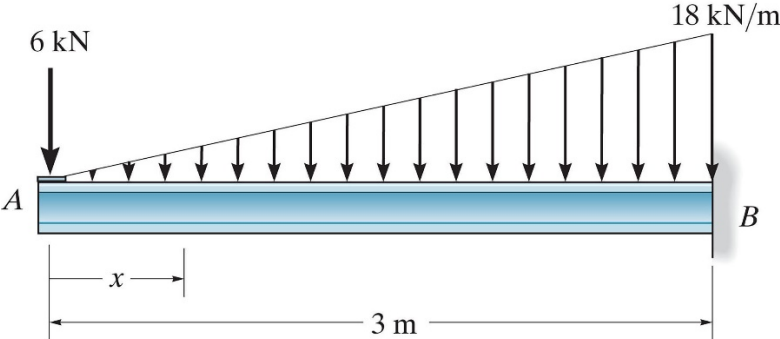

Example 4b-2 - Determine the internal shear and bending moment as a function of x .

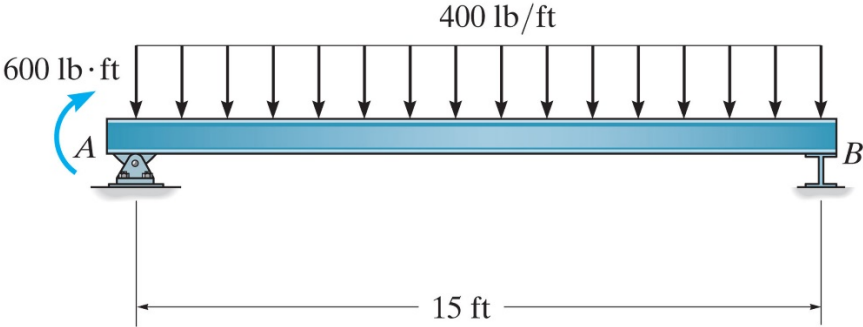

Example 4b-3 - Determine the internal shear and bending moment as a function of x .

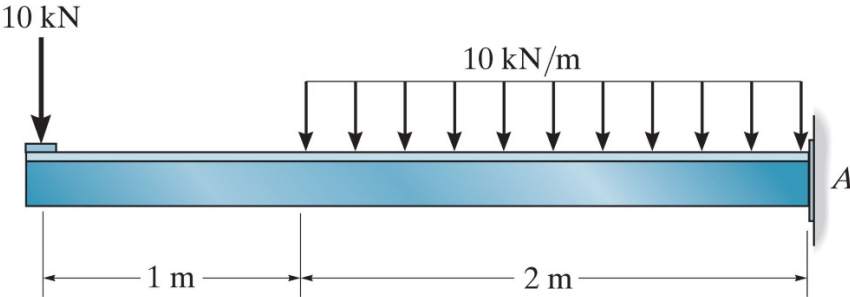

Example 4b-4 - Determine the internal shear and bending moment as a function of x .

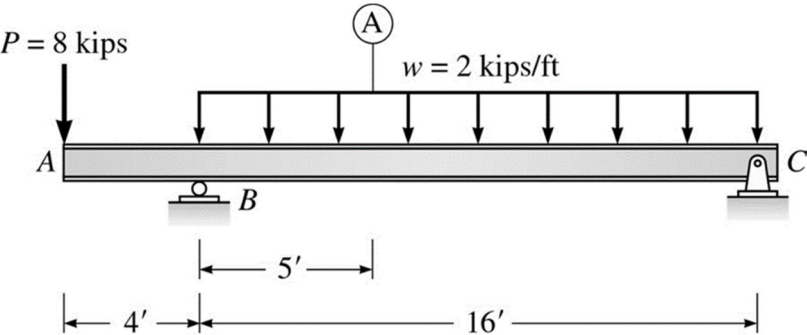

Example 4b-5 - Determine the internal shear and bending moment as a function of x .

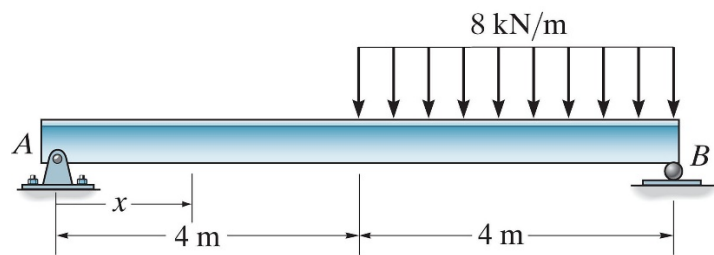

Example 4b-6 - Determine the internal shear and bending moment as a function of x .

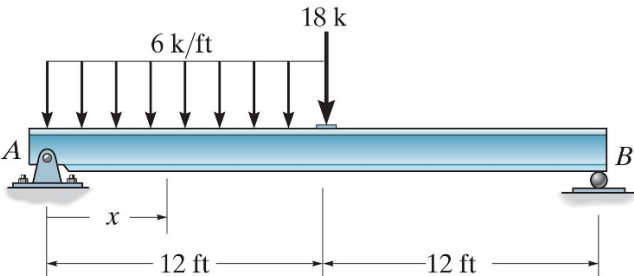

Example 4b-7 - Determine the internal shear and bending moment as a function of x .

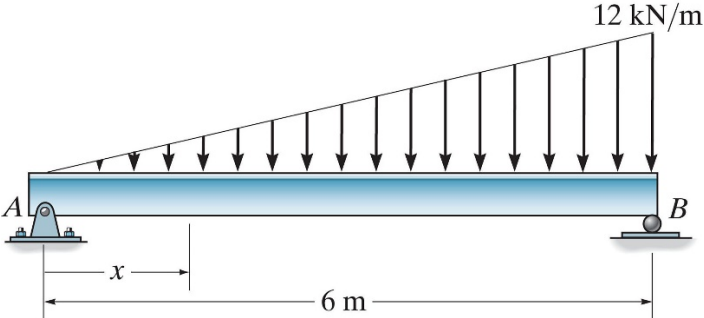

Example 4b-8 - Determine the internal shear and bending moment as a function of x .

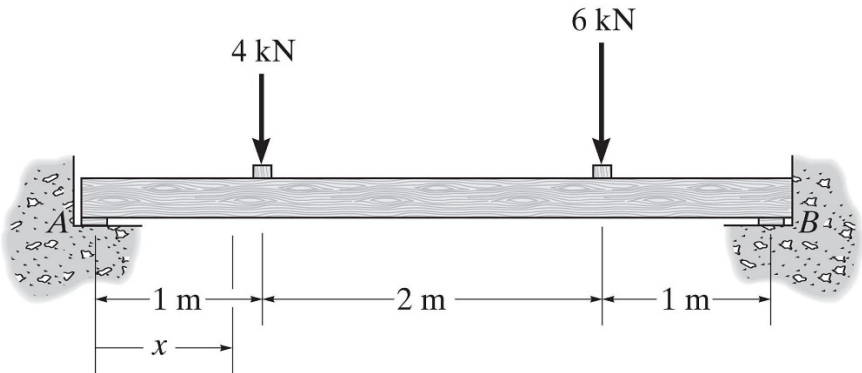

Example 4b-8 - Determine the internal shear and bending moment as a function of x .

